

# **CONCRETO ARMADO II**

## **EJERCICIOS RESUELTOS**

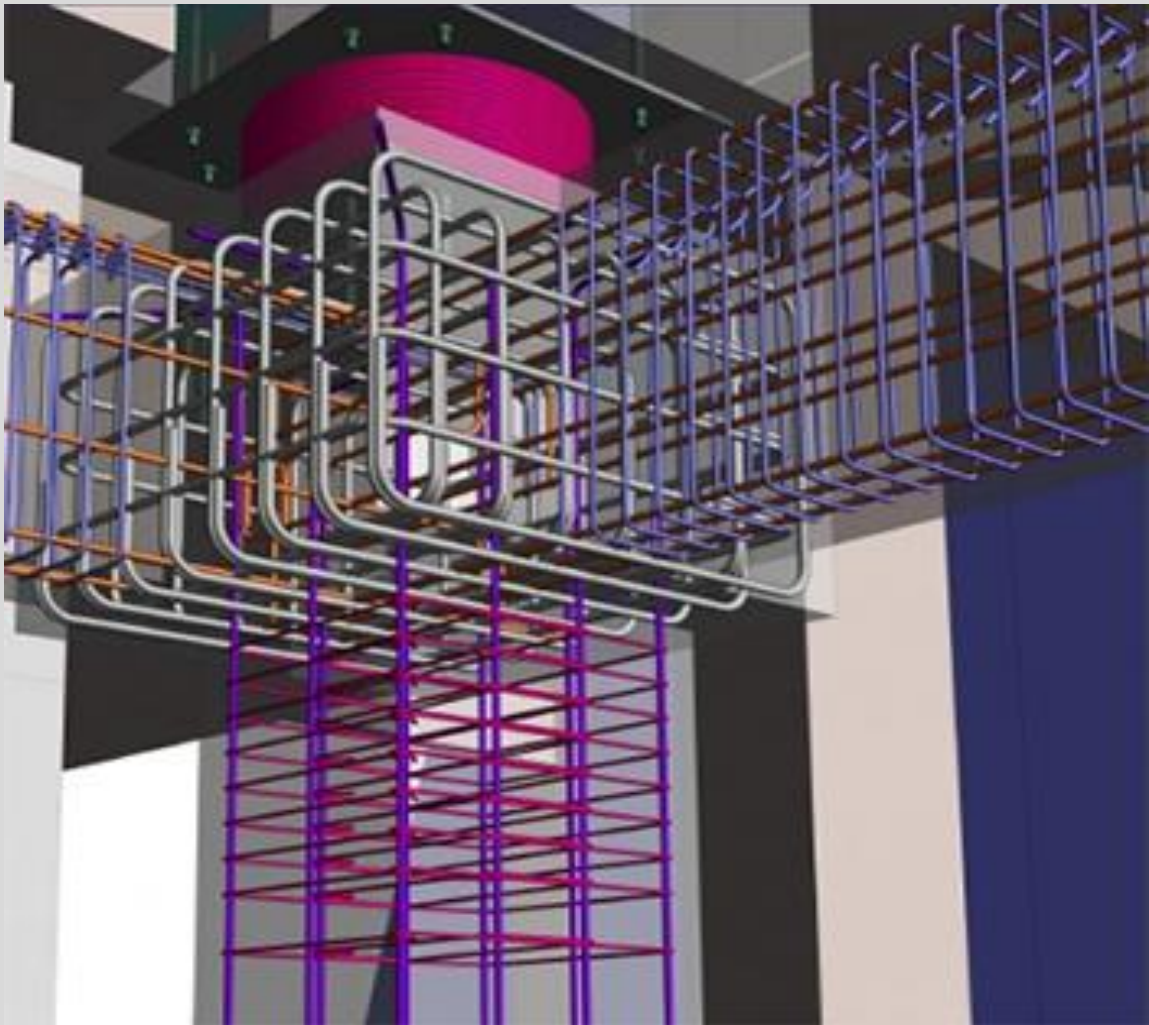

**"CIMENTACIONES II".**

ABRIL DEL  
2020

**PROBLEMA N° 02:**

Determinar, verificar y diseñar la zapata aislada mostrada en la figura adjunta que soporta una columna de sección rectangular de 0.30x0.60 m. (bxt) reforzada con 6 varillas # 8 y 6 varillas # 6, la carga que transmite a la columna es de Pd=180 ton, Pl=120 ton., el peso específico del suelo es de 1.50 ton/m<sup>3</sup> y la capacidad portante admisible del suelo según el (EMS) es de 2.50 kg/cm<sup>2</sup>, además está sometido a la acción de una sobrecarga de 500 kg/m<sup>2</sup>, emplear para el diseño fc=210 kg/cm<sup>2</sup> y fy=4200 kg/cm<sup>2</sup>.

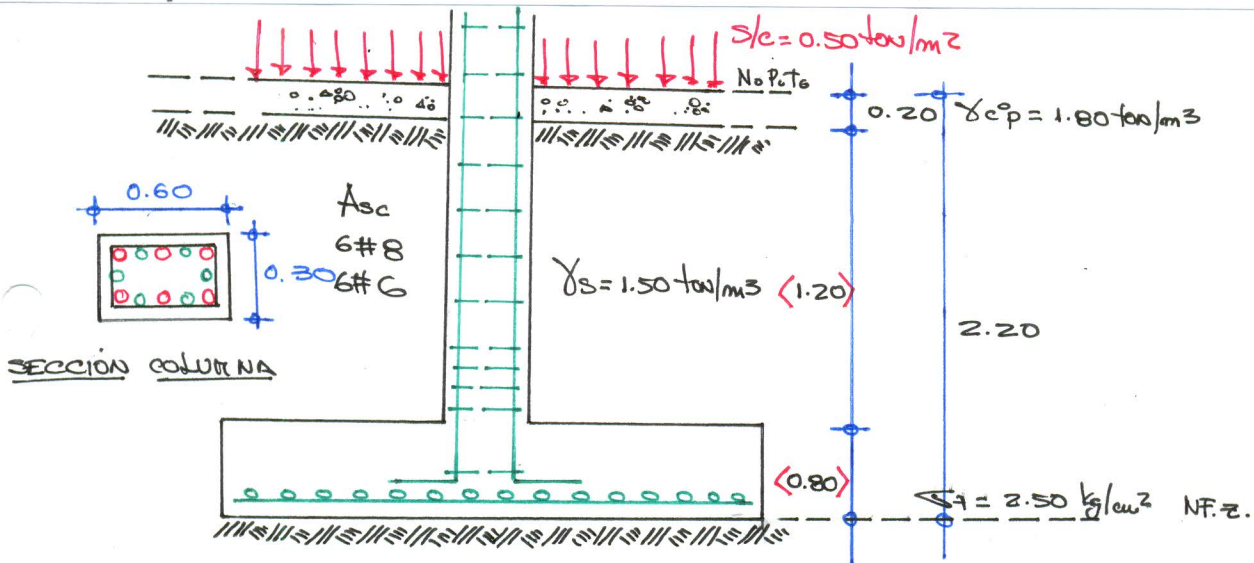

**⊕ DISEÑO Y VERIFICACIÓN DE LA ZAPATA :**

$$A_{s\text{COL}} \begin{cases} 6\#8 = 1'' \\ 6\#6 = 3/4'' \end{cases} \Rightarrow \text{ELEGIRIOS EL MAYOR } \#8 = 1'' \left\{ \begin{array}{l} D_b = 5.10 \text{ cm} \\ d_b = 2.54 \text{ cm} \end{array} \right.$$

"d" DEBE SER CAPAZ PARA PERMITIR EL DESARROLLO DEL REFUERZO EN COMPRESIÓN EN LA COLUMNA

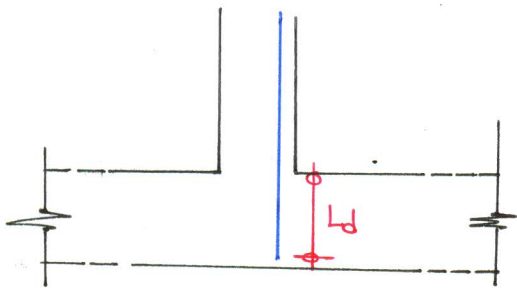

Normas Peruanas

$$L_d \text{ compresión} \begin{cases} L_d = 0.08 d_b f_y / \sqrt{f_c} \\ L_d = 0.004 d_b f_y \\ L_d \geq 20 \text{ cm} \end{cases}$$

$$L_d = 0.08 d_b f_y / \sqrt{f_c} = 0.08 (2.54) 4200 / \sqrt{210} = 58.893 \text{ cm.}$$

$$L_d = 0.004 d_b f_y = 0.004 (2.54) 4200 = 42.67 \text{ cm} \Rightarrow L_d = 60 \text{ cm.}$$

$$L_d \geq 20 \text{ cm} = 20 \text{ cm.}$$

$$\therefore d = L_d + 0.10 \Rightarrow d = 70 \text{ cm.} \Rightarrow h = d + \frac{\gamma + \phi}{0.10} \Rightarrow h = 80 \text{ cm.}$$

CAPACIDAD ESPECTIVA DEL TERRENO = CAPACIDAD PORTANTE NETA DEL TERRENO ( $q_e$ )

$$q_e = \sigma_t - (\gamma_e z h_z) - (\gamma_s h_s) - (\gamma_{cp} h_p) - s/c$$

$$q_e = 25 - (2.40 \times 0.80) - (1.50 \times 1.20) - (1.80 \times 0.20) - 0.50 \dots \rightarrow q_e = 20.42 \text{ ton/m}^2$$

$$q_e = 2.042 \text{ kg/cm}^2$$

AREA DE LA ZAPATA REQUERIDA:  $q_e = 20.42 \text{ ton/m}^2$ ,  $P_d = 180 \text{ ton}$ ,  $P_L = 120 \text{ ton}$ .

$$A = \frac{P_T}{q_e} \quad \Delta = \frac{P_d + P_L}{q_e} = \frac{180 + 120}{20.42} \Rightarrow A = 14.691 \text{ m}^2$$

DIMENSIONAMIENTO DE LOS LADOS DE LA ZAPATA:

$$A_z = (b + 2m)(t + 2m)$$

$$14.691 = (0.30 + 2m)(0.60 + 2m)$$

$$14.691 = 0.180 + 0.60m + 1.20m + 4m^2$$

$$4m^2 + 1.80m - 14.511 = 0$$

$$m_1 = 1.693 \text{ m}$$

$$m_2 = -2.143 \text{ m} \quad \circ \circ \quad m = 1.70 \text{ m}$$

$$B = b + 2m = 0.30 + (1.70)2 \Rightarrow B = 3.70 \text{ m}$$

$$L = t + 2m = 0.60 + (1.70)2 \Rightarrow L = 4.00 \text{ m}$$

$$\Rightarrow A_z = 14.80 \text{ m}^2$$

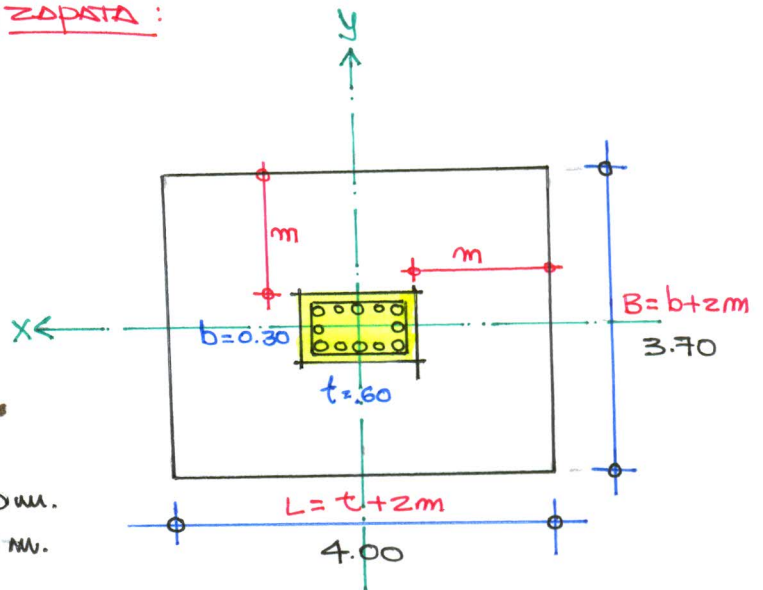

REACCION AMPLIFICADA DEL SUELO ( $q_u$ ) SEGUN RNE:  $P_u = 1.70 P_L + 1.40 P_d$

$$q_u = \frac{P_u}{A} = \frac{1.70 P_L + 1.40 P_d}{A} = \frac{1.70(120) + 1.40(180)}{14.80} \Rightarrow q_u = 30.811 \text{ ton/m}^2$$

$$q_u = 3.0811 \text{ kg/cm}^2$$

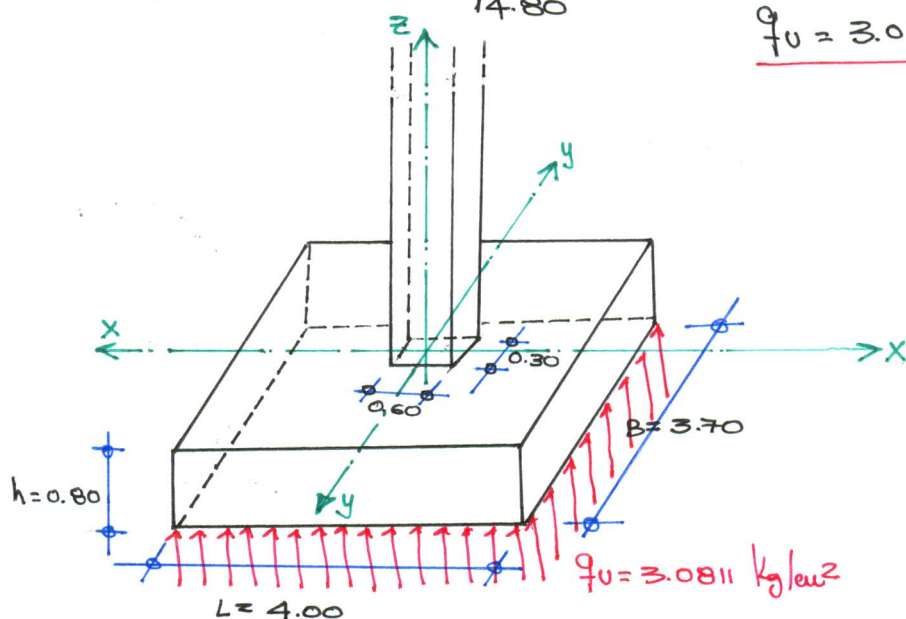



# VERIFICACION POR CORTE: FLEXION

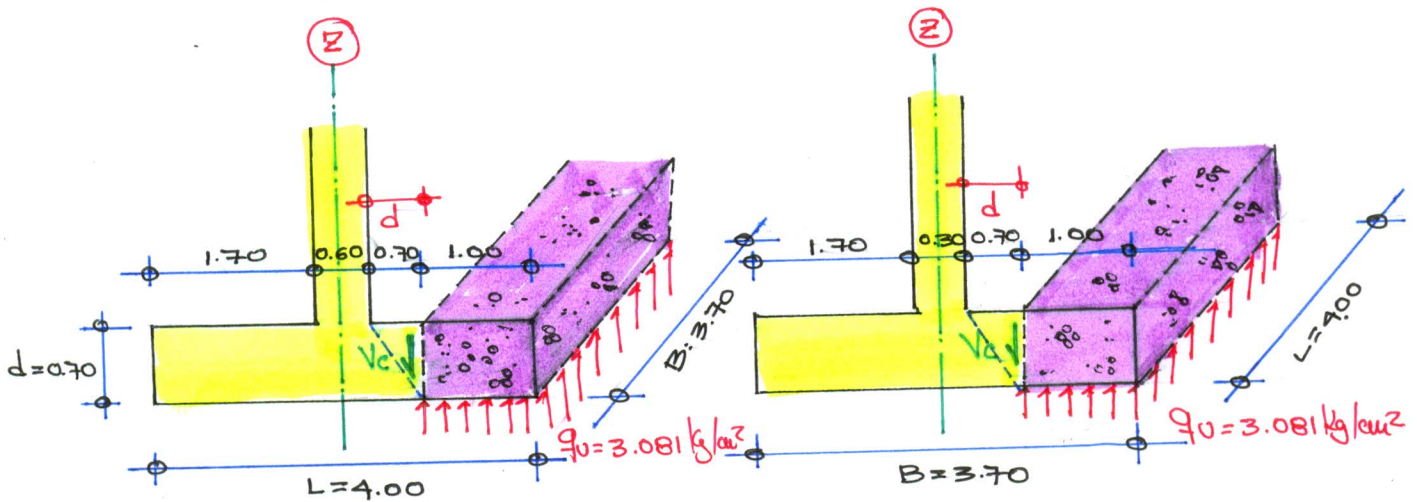

DIRECCION: X-X

DIRECCION: Y-Y

CONDICION NOMINATIVA

$$N_u \leq \phi V_c$$

Fuerza cortante ULTIMA      Resistencia del CONCRETO @ CORTE

$$N_u = q_u * \Delta$$

$$N_u = 3.081 * (1.00 * 3.70)$$

$$N_u = 113.997.00 \text{ kg} = 113.997 \text{ ton}$$

$$\phi V_c = \phi 0.53 \sqrt{f_c} * B * d$$

$$\phi V_c = 0.85 * 0.53 \sqrt{210} * 370 * 70$$

$$\phi V_c = 169.084.659 \text{ kg} = 169.084 \text{ ton}$$

$$N_u = 113.997 \text{ ton} < \phi V_c = 169.084 \text{ ton}$$

CONFORTE

$$N_u = q_u * \Delta$$

$$N_u = 3.081 (100 * 400)$$

$$N_u = 123.240.00 \text{ kg} = 123.240 \text{ ton}$$

$$\phi V_c = \phi 0.53 \sqrt{f_c} L * d$$

$$\phi V_c = 0.85 * 0.53 \sqrt{210} * 400 * 70$$

$$\phi V_c = 182.794.226 \text{ kg} = 182.794 \text{ ton}$$

$$N_u = 123.240 < \phi V_c = 182.794 \text{ ton}$$

CONFORTE

PERALTE NECESARIO (d\_mec)

$$q_u \Delta = \phi 0.53 \sqrt{f_c} L d$$

$$q_u (L_c * \cancel{L}) = \phi 0.53 \sqrt{f_c} \cancel{L} d$$

$$q_u L_c = \phi 0.53 \sqrt{f_c} d$$

$$L_c = 100 \text{ cm.}$$

$$d_{mec} = \frac{q_u L_c}{\phi 0.53 \sqrt{f_c}}$$

$$\Rightarrow d_{mec} = \frac{3.081 * 100}{0.85 * 0.53 \sqrt{210}} \Rightarrow d_{mec} = 47.194 \text{ cm}$$

$$d_{mec} = 47.194 \text{ cm.} < d_{max} = 70.00 \text{ cm}$$

CONFORTE



## VERIFICACION POR PUNZONAMIENTO:

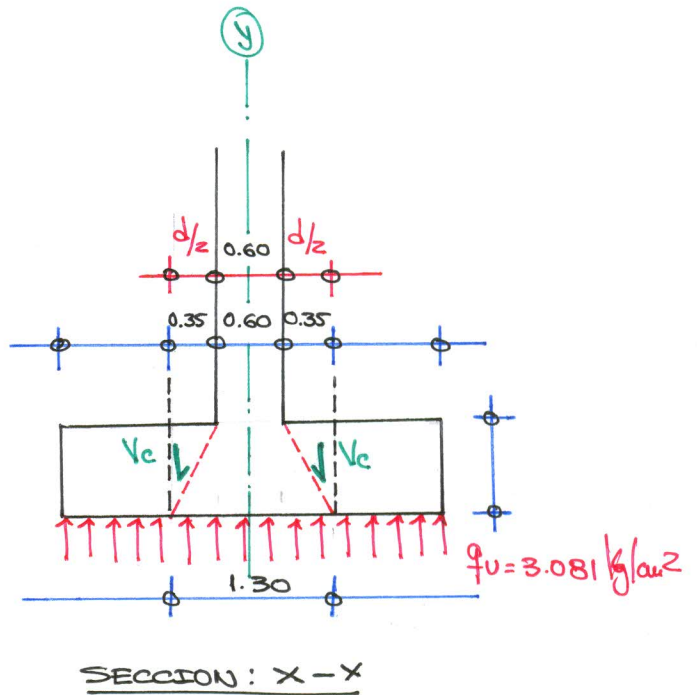
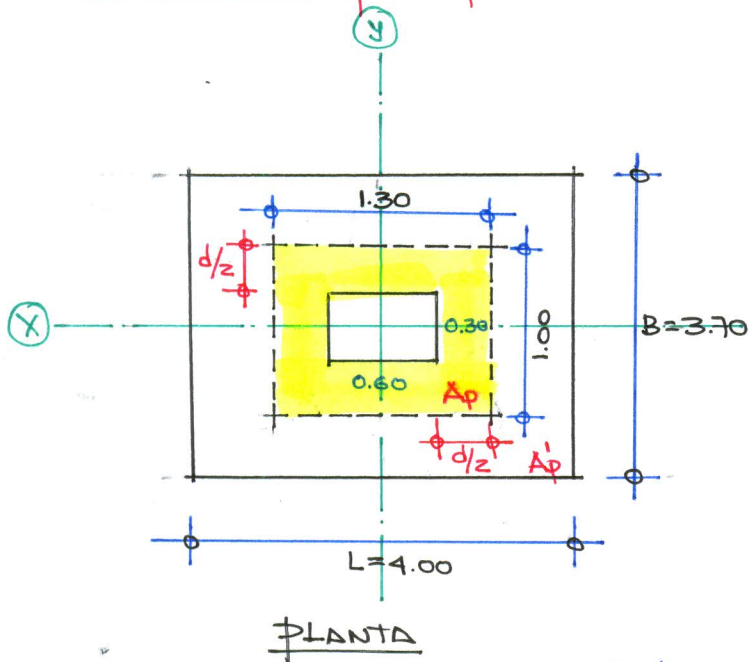

### CONDICION NORMATIVA

Fuerza cortante
 $V_u \leq \phi V_c$ 
RESISTENCIA DEL CONCRETO  
ULTIMA
@
CORTE

$$A'p = A_2 - A_p$$

$$A'p = (400 \times 370) - (130 \times 100)$$

$$A'p = 135000 \text{ cm}^2$$

$$V_u = q_u \times A'p$$

$$V_u = 3.081 \times 135000$$

$$V_u = 415935.00 \text{ kg} = 415.935 \text{ ton}$$

$$\beta_0 = \frac{1000 > \text{col.}}{1000 < \text{col.}} = \frac{0.60}{0.30} \Rightarrow \beta_0 = 2$$

### PERIMETRO DE PUNZONAMIENTO

$$b_0 = 2(100 + 130)$$

$$b_0 = 460.00 \text{ cm}$$

$$\phi V_c = \phi \left( 0.53 + \frac{1.10}{\beta_0} \right) \sqrt{f_c} b_0 d$$

$$\phi V_c = 0.85 \left( 0.53 + \frac{1.10}{2} \right) \sqrt{210} \times 460 \times 70$$

$$\phi V_c = 428359.30 \text{ kg} = 428.359 \text{ ton}$$

$$\therefore V_u = 415.935 \text{ ton} < \phi V_c = 428.359 \text{ ton}$$

### CONFORTE

#### PERDUTE NECESARIO $d_{mec}$

$$V_0 b_0 d = q_u A'p$$

$$d_{mec} = \frac{q_u A'p}{V_0 b_0} = \frac{3.081(135000)}{13.549 \times 460}$$

$$d_{mec} = 66.736 \text{ cm}$$

$$V_0 = \phi 1.10 \sqrt{210}$$

$$V_0 = 0.85 \times 1.10 \sqrt{210}$$

$$V_0 = 13.549 \text{ kg}$$

$$\therefore d_{mec} = 66.736 \text{ cm} < d_{col} = 70.00 \text{ cm}$$

### CONFORTE

# DISEÑO POR FLEXIÓN:

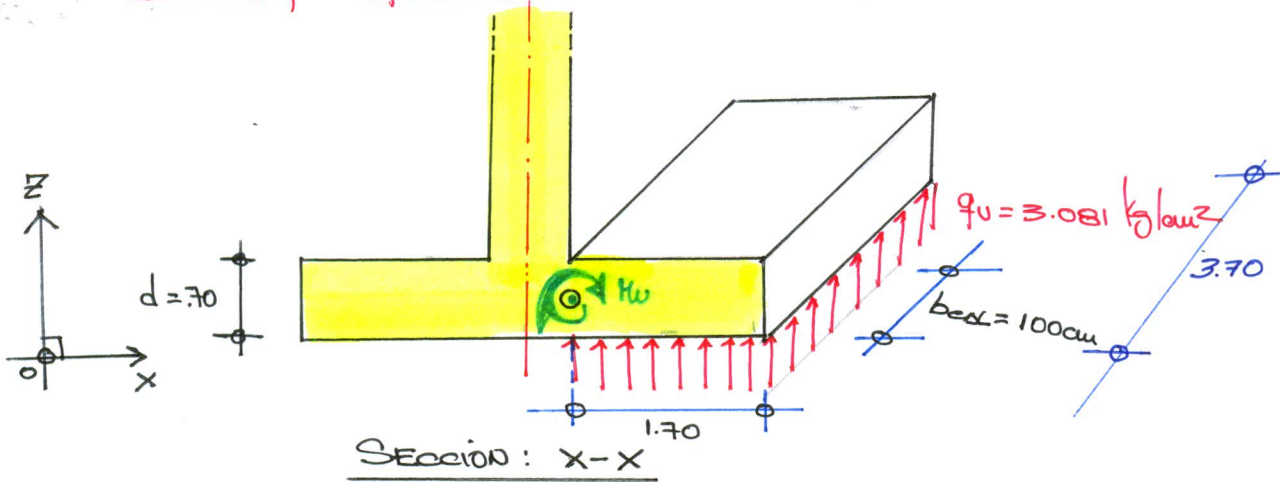

$$M_w = \frac{q_u L^2}{2} b_{ed} \Rightarrow M_w = \frac{3.081 (1.70)^2 (100)}{2} \Rightarrow M_w = 44.52 \text{ ton-m}$$

## DATOS DE DISEÑO

$$b = 100 \text{ cm}$$

$$d = 70 \text{ cm}$$

$$f_c = 210 \text{ kg/cm}^2$$

$$f_y = 4200 \text{ kg/cm}^2$$

$$M_w = 44.52 \text{ ton-m}$$

$$a = \frac{A_s f_y}{0.85 f_c b}$$

$$M_w = \phi A_s f_y (d - \frac{a}{2})$$

$$0.59 \omega^2 - \omega + \frac{M_w}{\phi b d^2 f_c} = 0$$

$$\omega = \frac{\rho f_y}{d f_c}, \quad \rho = \frac{A_s d}{b d}, \quad \rho = \omega \frac{f_c}{f_y}, \quad A_s d = \rho b d$$

$$\rho_{min} = \frac{0.70 \sqrt{f_c}}{f_y}$$

$$\Rightarrow \rho_{min} = 0.00242$$

$$A_{smin} = \rho_{min} b d \Rightarrow A_{smin} = 16.9066 \text{ cm}^2$$

$$\rho_b = 0.85 \beta_1 \frac{f_c}{f_y} \left( \frac{6000}{6000 + f_y} \right) \Rightarrow \rho_b = 0.02125$$

$$A_{sb} = \rho_b b d \Rightarrow A_{sb} = 148.75 \text{ cm}^2$$

$$\rho_d = \Rightarrow \rho_d = 0.00248$$

$$A_{sd} = \rho_d b d \Rightarrow A_{sd} = 17.33177 \text{ cm}^2$$

$$\rho_{max} = 0.75 \rho_b \Rightarrow \rho_{max} = 0.01594$$

$$A_{smax} = \rho_{max} b d \Rightarrow A_{smax} = 111.562 \text{ cm}^2$$

$$\rho_d < \rho_{max} < \rho_b \quad \therefore \text{falla ductil}$$

## DISTRIBUCIÓN DE ACEROS:

$$A_{std} = 17.332 * 3.70 \Rightarrow A_{std} = 64.128 \text{ cm}^2$$

$$\phi 3/4'' = 2.84 \text{ cm}^2$$

$$n = \frac{A_{std}}{A_{s\phi}} \Rightarrow n = \frac{64.128}{2.84} \Rightarrow n = 22.58 \Rightarrow n = 23 \text{ UNIDADES}$$

## ESPACIAMIENTO:

$$d_b \phi 3/4 = 0.019 \text{ m}$$

$$S = \frac{B - 2(r) - \phi - 0.10}{n - 1} = \frac{3.70(2 * 0.075) - 0.019 - 0.10}{22} \Rightarrow S = 0.156 \text{ cm}$$

$$23 \phi 3/4 @ 0.156 \text{ cm} :$$

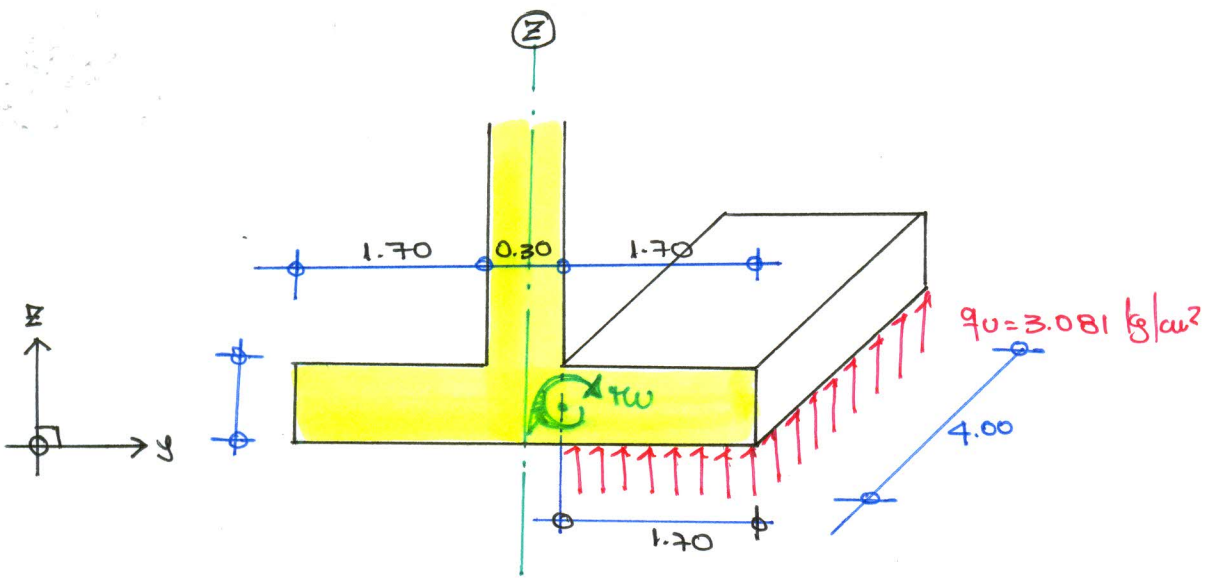

SECCION: y-y

$$\tau_w = \frac{q_u L^2 b_{\text{base}}}{2} \Rightarrow \tau_w = \frac{3.081 \times 1.70^2 \times 100}{2} \Rightarrow \tau_w = 44.52 \text{ ton-m}$$

DATOS DE DISEÑO:

$$b = 100 \text{ cm}$$

$$d = 70 \text{ cm}$$

$$f_c = 210 \text{ kg/cm}^2$$

$$f_y = 4200 \text{ kg/cm}^2$$

$$\tau_w = 44.52 \text{ ton-m}$$

$$a = \frac{A_s f_y}{0.85 f_c b} \quad \tau_w = \phi A_s f_y \left(d - \frac{a}{2}\right)$$

$$0.59 w^2 - w - \frac{\tau_w}{\phi b d^2 f_c} = 0$$

$$w = \phi_d \frac{f_y}{f_c}, \quad \phi_d = w \frac{f_c}{f_y}, \quad A_{sd} = \phi_d b d$$

$$\phi_{\text{min}} = \frac{0.70 \sqrt{f_c}}{f_y}$$

$$\Rightarrow \phi_{\text{min}} = 0.00242 \rightarrow A_{s\text{min}} = \phi_{\text{min}} b d \Rightarrow A_{s\text{min}} = 16.906 \text{ cm}^2$$

$$\phi_b = 0.85 \beta \frac{f_c}{f_y} \left(\frac{6000}{6000 + f_y}\right) \Rightarrow \phi_b = 0.02125 \rightarrow A_{sb} = \phi_b b d \Rightarrow A_{sb} = 148.75 \text{ cm}^2$$

$$\phi_d = \phi_d = 0.00248 \rightarrow A_{sd} = \phi_d b d \Rightarrow A_{sd} = 17.332 \text{ cm}^2$$

$$\phi_{\text{max}} = 0.75 \phi_d \Rightarrow \phi_{\text{max}} = 0.01594 \rightarrow A_{s\text{max}} = \phi_{\text{max}} b d \Rightarrow A_{s\text{max}} = 111.562 \text{ cm}^2$$

$\phi_d < \phi_{\text{max}} < \phi_b$  ∴ falla dúctil

Distribución de Acero:  $A_{sd} = 17.332(4) \Rightarrow A_{sd} = 69.328 \text{ cm}^2$

$$A_{s\phi 3/4} = 2.84 \text{ cm}^2 \quad d_b = 0.019 \text{ m}$$

# ACEROS

$$m = \frac{A_{sd}}{A_{s\phi}} \Rightarrow m = \frac{69.328}{2.84} \Rightarrow m = 24.411 \Rightarrow m = 25 \text{ UNIDADES}$$

ESPACIAMIENTO:

$$s = \frac{L - 2r - \phi - 0.10}{m - 1} = \frac{4.00 - 0.15 - 0.019 - 0.10}{24} \Rightarrow s = 0.155 \text{ cm}$$

$$25 \phi 3/4 @ 0.155$$



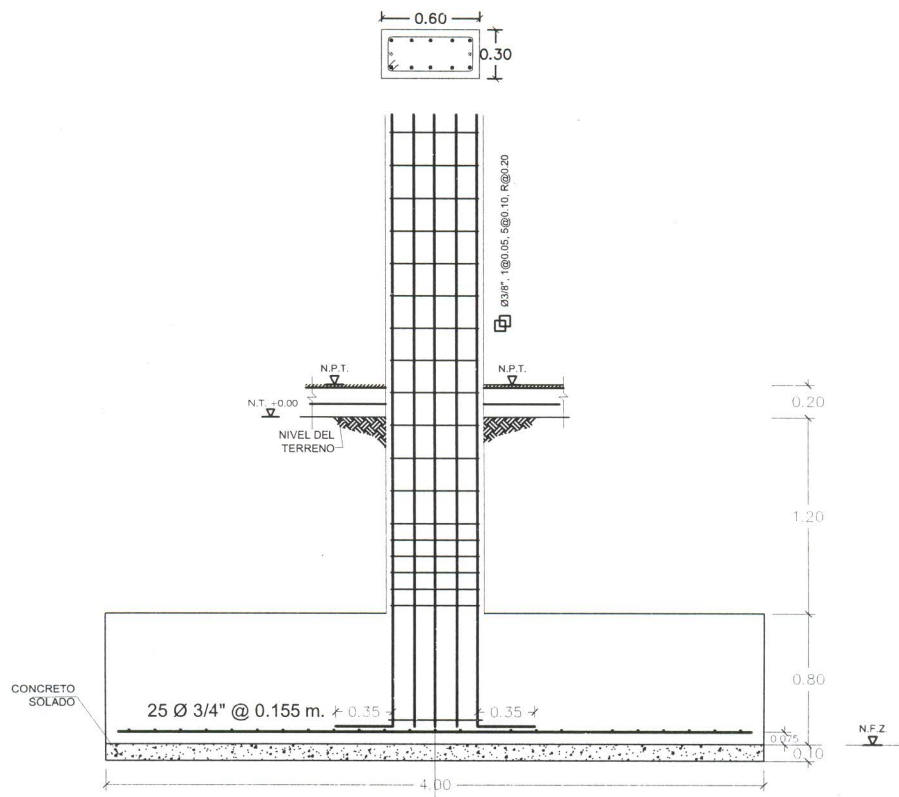

DETALLE DE ZAPATA TÍPICO  
ESCALA 1:25

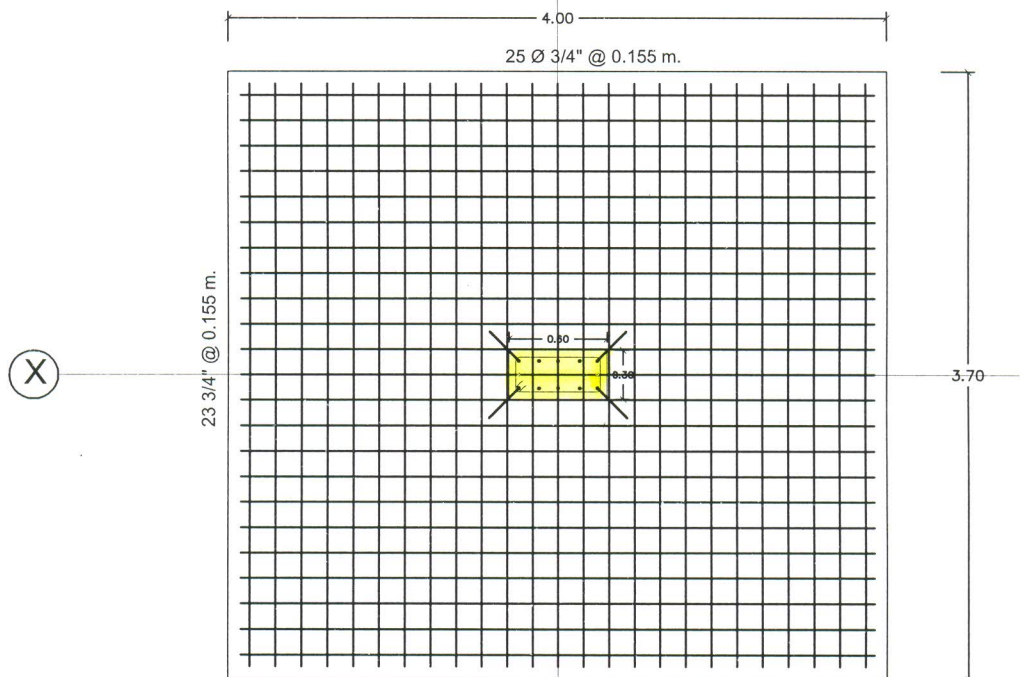

DETALLE DE ZAPATA EN PLANTA

ESCALA 1:25

PROBLEMA #03:

DISEÑAR LA ZAPATA AISLADA CONSIDERANDO LOS DATOS TÉCNICOS Y ESTRUCTURALES

$P_{cm} = 92.50 \text{ ton}$   
 $P_{cv} = 73.00 \text{ ton}$

$M_{cm} = 36.50 \text{ ton-m}$   
 $M_{cv} = 22.50 \text{ ton-m}$

$\sigma_f = 2.125 \text{ kg/cm}^2$

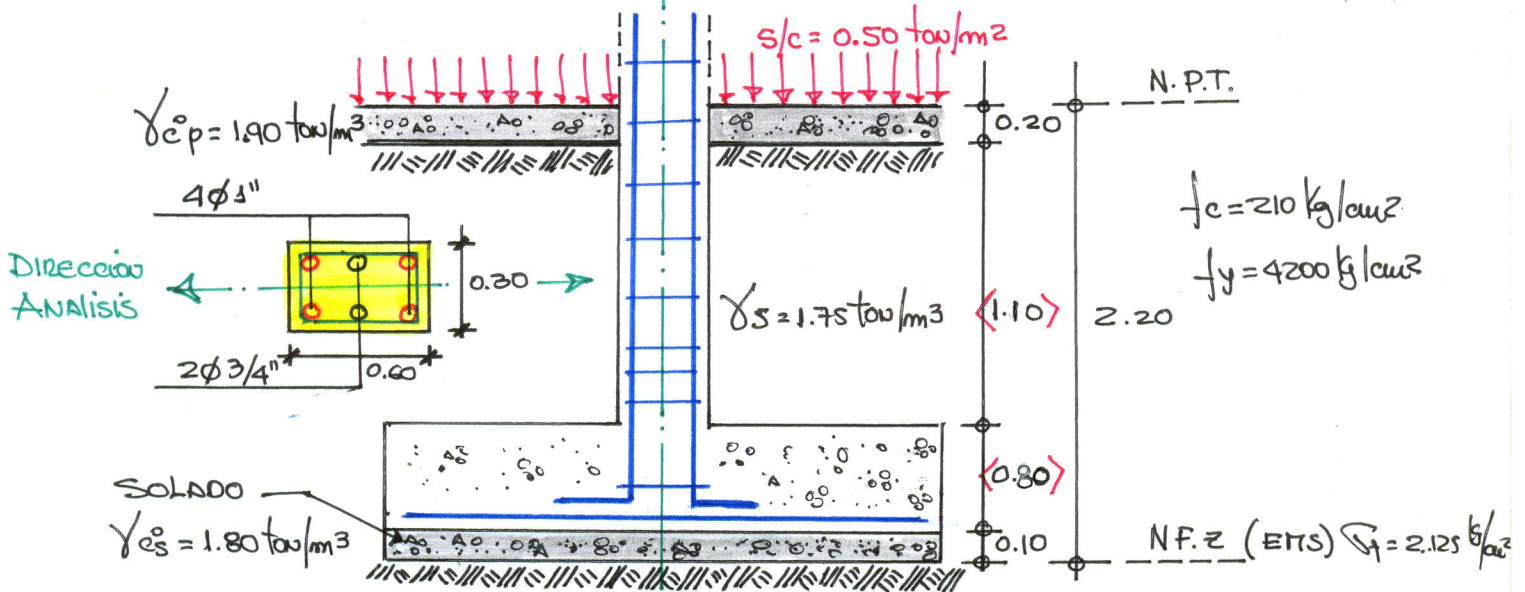

I): DIMENSIONAMIENTO

PERALTE DE LA ZAPATA:

$A_{s \text{ col}} = 4\phi 1" + 2\phi 3/4 \Rightarrow \phi 1" \left\{ \begin{array}{l} d_b = 2.54 \text{ cm.} \\ A_b = 5.10 \text{ cm}^2. \end{array} \right.$

CONSIDERACIONES NORMATIVAS:

$$\left. \begin{array}{l} l_d = 0.08 d_b f_y / \sqrt{f_c} = 58.893 \text{ cm.} \\ l_d = 0.004 d_b f_y = 42.672 \text{ cm.} \\ l_d \geq 20 \text{ cm.} \end{array} \right\} \begin{array}{l} l_d = 58.893 \\ l_d = 60.00 \text{ cm.} \end{array}$$

$\therefore d = l_d + 10 \text{ cm} \Rightarrow d = 70.00 \text{ cm.} \Rightarrow h = d + 10 \text{ cm} \Rightarrow h = 80.00 \text{ cm}$

CAPACIDAD PORTANTE NETA DEL TERRENO (qe)

$$q_e = \sigma_f - (\gamma_{cs} * h_s) - (\gamma_{cz} * h_z) - (\gamma_s * h_s) - (\gamma_{cp} * h_p) - s/c$$

$$q_e = 2.125 - (1.80 * 0.10) - (2.40 * 0.80) - (1.75 * 1.10) - (1.90 * 0.20) - 0.50$$

$$q_e = 16.345 \text{ ton/m}^2 = 1.6345 \text{ kg/cm}^2$$

AREA DE LA ZAPATA:

$$A = \frac{P_T}{q_e} \Rightarrow A = \frac{P_{cm} + P_{cv}}{q_e} \Rightarrow \frac{92.50 + 73.00}{16.345} \Rightarrow A = 10.125 \text{ m}^2$$

$$A = (t + 2m)(b + 2m)$$

$$10.125 = (0.60 + 2m)(0.30 + 2m)$$

$$10.125 = 0.18 + 1.20m + 0.60m + 4m^2$$

$$4m^2 + 1.8m - 9.945 = 0$$

$$m = 1.368 \text{ m.}$$

$$L = t + 2m = 0.60 + 2(1.368) \Rightarrow L = 3.336 \text{ m}$$

$$B = b + 2m = 0.30 + 2(1.368) \Rightarrow B = 3.036 \text{ m}$$

$$\circ \circ L = 3.30, B = 3.00, A = 9.90 \text{ m}^2$$

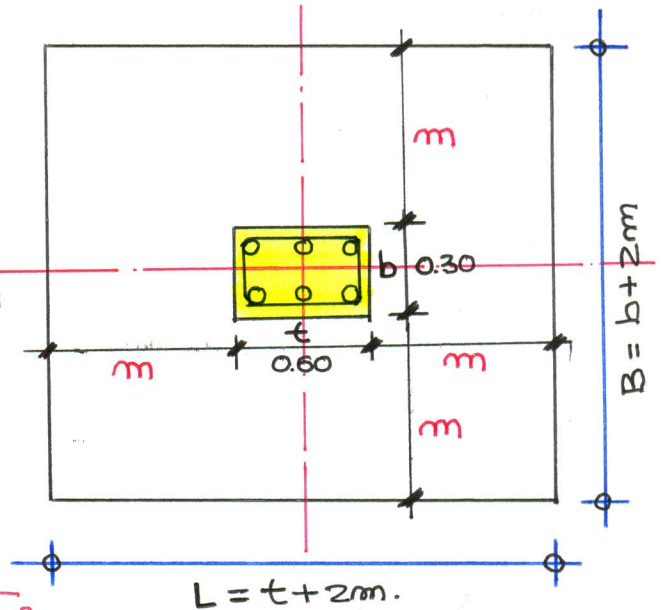

### VERIFICACION DE PRESION $\sigma_{MAX} < \sigma_f$

$$P_s = P_{ext} + P_{ex} = 92.50 + 73.00 \Rightarrow P_s = 165.50 \text{ ton}$$

$$M_s = M_{ext} + M_{ex} = 36.50 + 22.50 \Rightarrow M_s = 59.00 \text{ ton-m}$$

$$\sigma_{MAX} = \frac{P_s}{A} + \frac{M_s c}{I}$$

$$A = 9.90 \text{ m}^2$$

$$c = L/2 \Rightarrow c = 1.65 \text{ m.}$$

$$I = \frac{BL^3}{12} \Rightarrow I = 8.984 \text{ m}^4$$

$$\sigma_{MAX} = \frac{165.50}{9.90} + \frac{59.00(1.65)}{8.984}$$

$$\sigma_{MAX} = 27.553 \text{ ton/m}^2 > \sigma_f = 21.25 \text{ ton/m}^2 \quad (\text{No cumple la Condicion})$$

### REDIMENSIONAMOS BY L

$$B = 3.40 \text{ m}, L = 3.70 \text{ m}, A = 12.58 \text{ m}^2, c = 1.85 \text{ m}, I = 14.352 \text{ m}^4$$

$$\sigma_{MAX} = \frac{P_s}{A} + \frac{M_s \times c}{I}$$

$$\sigma_{MAX} = \frac{165.50}{12.58} + \frac{59.00(1.85)}{14.352} \Rightarrow \sigma_{MAX} = 20.761 \text{ ton/m}^2$$

$$\circ \circ \sigma_{MAX} = 20.761 \text{ ton/m}^2 < \sigma_f = 21.25 \text{ ton/m}^2$$

(CONFORME)



CARGAS DE DISEÑO (Pu, Mw)

REACCIÓN AMPLIFICADA DEL SUELO:

$P_{cm} = 92.50 \text{ ton}$        $M_{cm} = 36.50 \text{ ton-m.}$   
 $P_{cv} = 73.00 \text{ ton}$        $M_{cv} = 22.50 \text{ ton-m.}$

$P_u = 1.70 P_{cv} + 1.40 P_{cm} = 1.70(73.00) + 1.40(92.50) \Rightarrow 253.60 \text{ ton}$

$M_u = 1.70 M_{cv} + 1.40 M_{cm} = 1.70(22.50) + 1.40(36.50) \Rightarrow 89.35 \text{ ton-m.}$

$e = \frac{M_u}{P_u} = \frac{89.35}{253.60} \Rightarrow e = 0.352 \text{ m.}$

$\frac{L}{6} = \frac{3.70}{6} \Rightarrow \frac{L}{6} = 0.617 \text{ m}$        $\infty e = 0.352 < \frac{L}{6} = 0.617$

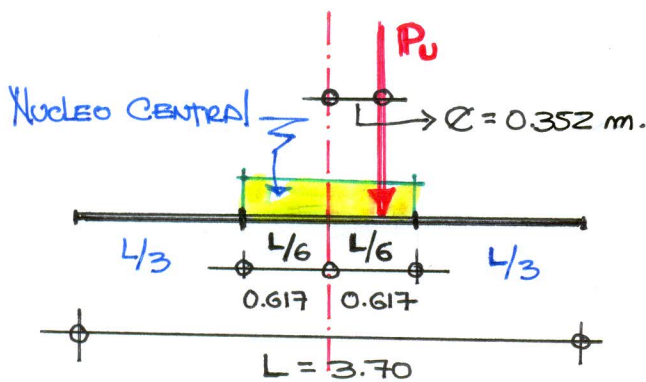

Presión de contacto forma TRAPEZOIDAL

Presiones para el diseño (Método de Resistencia Última)

$\sigma_{1,2} = \frac{P_u}{A} \pm \frac{M_u \cdot c}{I}$

$\sigma_{1,2} = \frac{253.60}{12.58} \pm \frac{89.35(1.85)}{14.352}$

$\sigma_{1,2} = \begin{cases} \sigma_1 = 31.676 \text{ ton/m}^2 \\ \sigma_2 = 8.642 \text{ ton/m}^2 \end{cases}$

- $P_u = 253.60 \text{ ton}$
- $M_u = 89.35 \text{ ton-m.}$
- $L = 3.70 \text{ m}$
- $B = 3.40 \text{ m.}$
- $A = 12.58 \text{ m}^2$
- $c = 1.85 \text{ m}$
- $I = 14.352 \text{ m}^4$

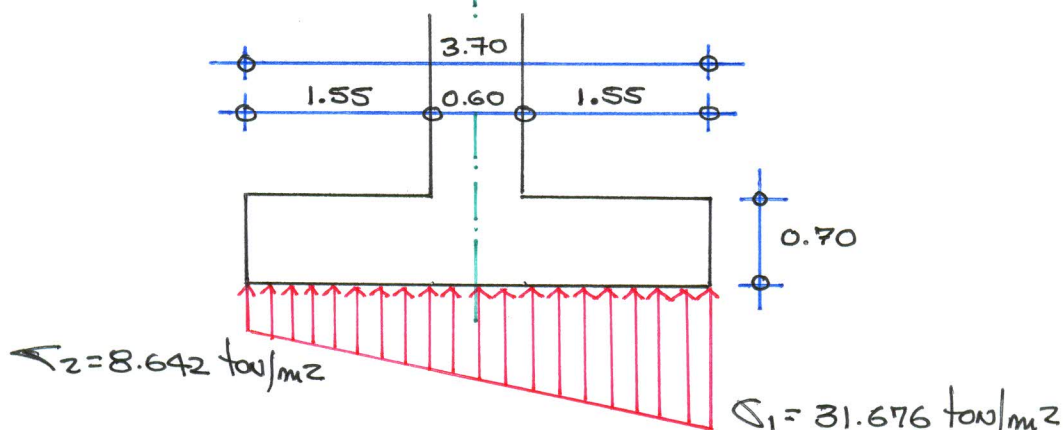

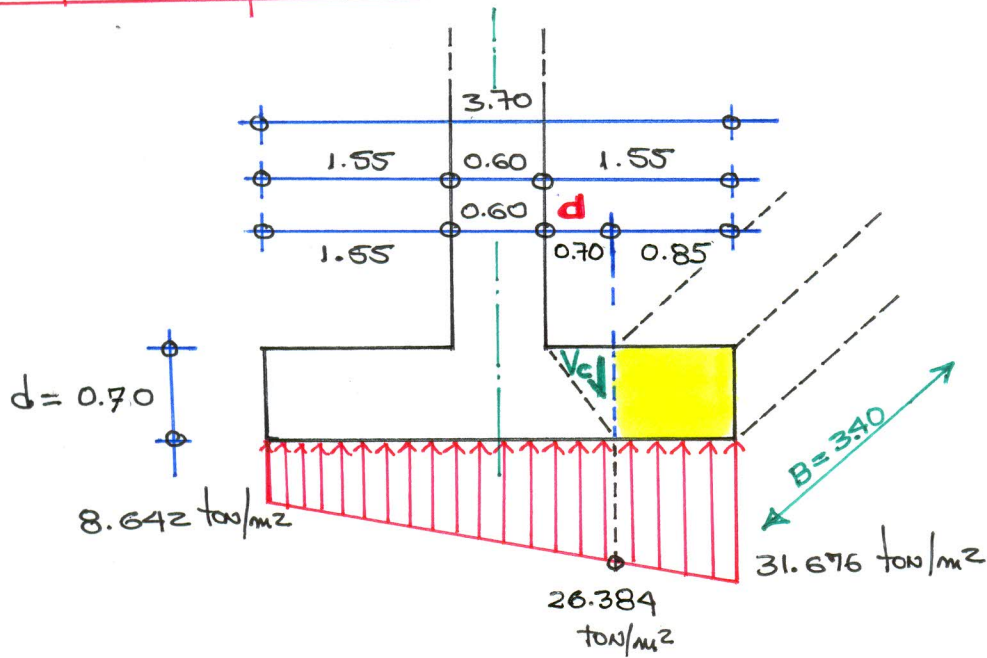
VERIFICACION POR CORTANTE

$$V_u \leq \phi V_c$$

FUERZA CORTANTE ULTIMA  $\leftrightarrow$  RESISTENCIA DEL CONCRETO @ CORTE

$$V_u = \left[ \frac{(31.676 + 26.384) \cdot 0.85}{2} \right] \cdot 3.40$$

$$V_u = 83.897 \text{ ton} = 83896.700 \text{ kg}$$

$$\phi V_c = \phi \cdot 0.53 \sqrt{f_c} \cdot B \cdot d$$

$$\phi V_c = 0.85 \cdot 0.53 \sqrt{210} \cdot 340 \cdot 70$$

$$\phi V_c = 155.375 \text{ ton} = 155375.092 \text{ kg}$$

$$\therefore V_u = 83.897 \text{ ton} < \phi V_c = 155.375 \text{ ton}$$

CONFORME

VERIFICACION POR PUNZONAMIENTO

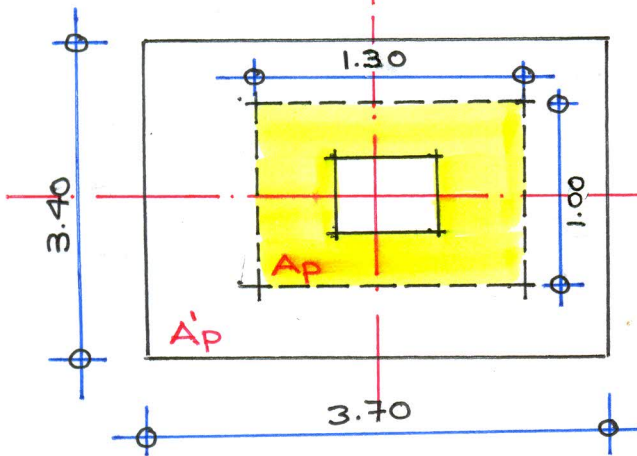
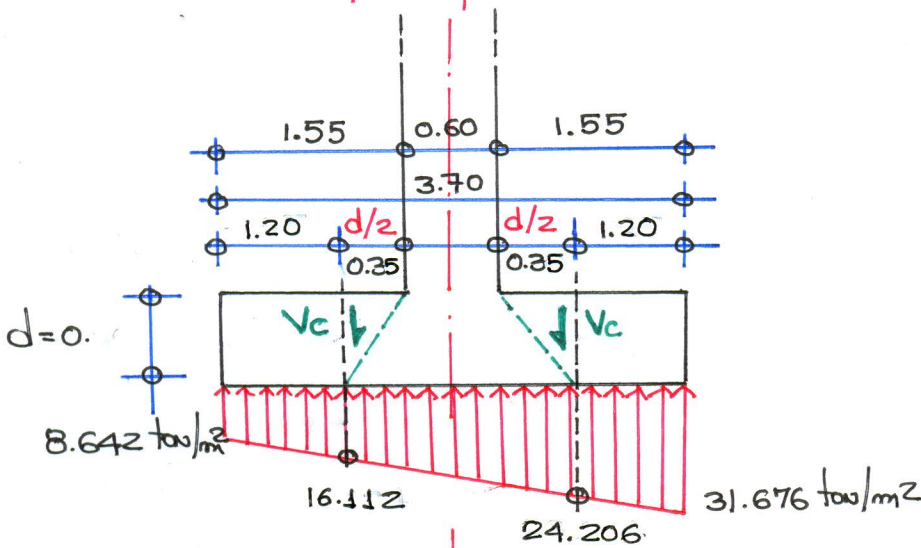

PERIMETRO DE PUNZONAMIENTO

$$b_0 = 2(1.30) + 2(1.00) \Rightarrow b_0 = 4.60 \text{ m}$$

Relacion LADOS DE COLUMNA

$$\beta_0 = \frac{\text{LADO MAYOR COL.}}{\text{LADO MENOR COL.}}$$

$$\beta_0 = \frac{0.60}{0.20} \Rightarrow \beta_0 = 3$$

$$A'_p = A_z - A_p$$

$$A'_p = (3.70 \times 3.40) - (1.30 \times 1.00)$$

$$A'_p = 11.2800 \text{ m}^2$$

Fuerza Cortante Ultima  $\uparrow$   $V_u \leq \phi V_c$  Resistencia del Concreto @ corte Punzonamiento  $\uparrow$

$$V_u = q_u A'_p$$

$$\phi V_c = \phi \left( 0.53 + \frac{1.10}{\beta_0} \right) \sqrt{f_c} b_0 d$$

$$V_u = \left[ \frac{(31.676 + 8.642) \cdot 3.70 \cdot (3.40)}{2} \right] - \left[ \frac{(24.206 + 16.112) \cdot 1.30 \cdot (1.00)}{2} \right]$$

$$V_u = 227.394 \text{ ton} = 227393.520 \text{ kg}$$

$$\phi V_c = 0.85 \left( 0.53 + \frac{1.10}{2} \right) \sqrt{210} \cdot 4.60 \cdot 0.25$$

$$\phi V_c = 428.359 \text{ ton} = 428359.300 \text{ kg}$$

$$V_u = 227.394 \text{ ton} < \phi V_c = 428.359 \text{ ton}$$

CONFORME

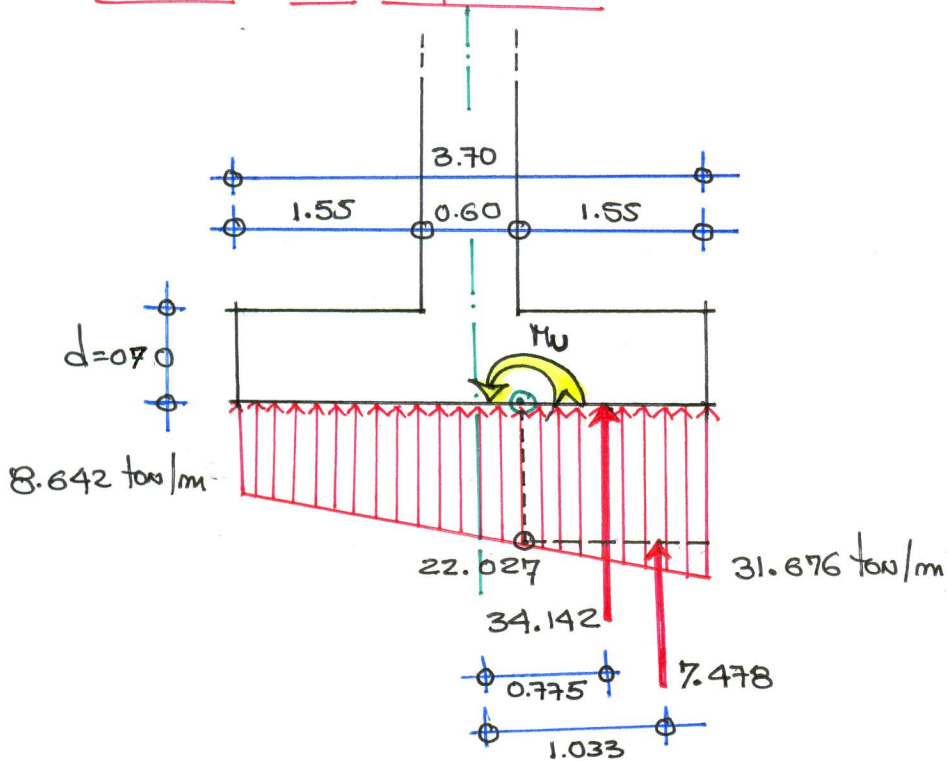

DISEÑO DE REFUERZO:

$$M_u = 34.142(0.775) + 7.478(1.033) \Rightarrow M_u = 34.185 \text{ ton-m}$$

DISEÑO DE REFUERZO LONGITUDINAL

DATOS DE DISEÑO:

$$M_u = 34.185 \text{ ton-m}, \quad b = 100 \text{ cm}, \quad d = 70 \text{ cm}, \quad f_c = 210 \text{ kg/cm}^2, \quad f_y = 4200 \text{ kg/cm}^2$$

$$a = \frac{A_s f_y}{0.85 f_c b}$$

$$M_u = \phi A_s f_y \left(d - \frac{a}{2}\right)$$

$$P_{\min} = \frac{0.70 \sqrt{f_c}}{f_y} \Rightarrow P_{\min} = 0.00242 \Rightarrow A_{s\min} = P_{\min} b d \Rightarrow A_{s\min} = 16.906 \text{ cm}^2$$

$$P_b = 0.85 \beta_1 \frac{f_c}{f_y} \left(\frac{6000}{6000 + f_y}\right) \Rightarrow P_b = 0.0225 \Rightarrow A_{sb} = P_b b d \Rightarrow A_{sb} = 148.75 \text{ cm}^2$$

$$P_{\max} = 0.75 P_b \Rightarrow P_{\max} = 0.01594 \Rightarrow A_{s\max} = P_{\max} b d \Rightarrow A_{s\max} = 111.563 \text{ cm}^2$$

$$P_b = w \frac{f_c}{f_y} \Rightarrow P_d = 0.00189 \Rightarrow A_{sd} = P_d b d \Rightarrow A_{sd} = 13.214 \text{ cm}^2$$

$$A_s \phi 3/4 = 2.84 \text{ cm}^2 \quad db \phi 3/4 = 1.905 \text{ cm} = 0.01905 \text{ m}$$

$$A_{sd} < A_{s\min} \Rightarrow A_{sd} = A_{s\min} = 16.906 \text{ cm}^2$$

Numero de varillas  $A_{std} = A_{sd} (3.40) \Rightarrow A_{std} = 57.480 \text{ cm}^2$

$$N = \frac{A_{std}}{A_{s\phi}} \Rightarrow N = \frac{57.480}{2.84} \Rightarrow N = 20.24 \Rightarrow N = 20 \text{ UNIDADES.}$$

Distribucion de Acero:

$$S = \frac{B - 2r - \phi - 0.10}{N-1} \Rightarrow S = \frac{3.40 - 2(0.075) - 0.01905 - 0.10}{1} \Rightarrow S = 0.165 \text{ m}$$

∞ Acero longitudinal: 20  $\phi 3/4 @ 0.165 \text{ m.}$

DISEÑO DE ACERO TRANSVERSAL ∞

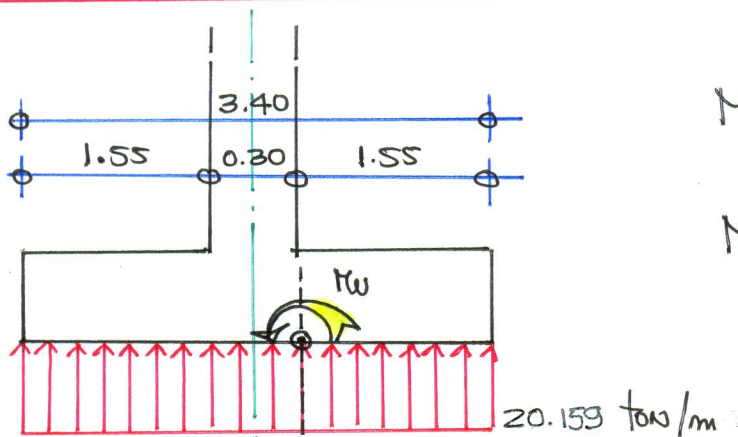

$$M_u = \frac{qL^2}{2} = \frac{20.159 (1.55)^2}{2}$$

$$M_u = 24.216 \text{ ton-m}$$

DATOS DE DISEÑO:  $M_u = 24.216 \text{ ton-m}$ ,  $b = 100 \text{ cm}$ ,  $d = 70 \text{ cm}$ ,  $f_c = 210 \text{ kg/cm}^2$ ,  $f_y = 4200 \text{ kg/cm}^2$

$$P_{min} = \frac{0.70 \sqrt{f_c}}{f_y} \Rightarrow P_{min} = 0.00242 \Rightarrow A_{smin} = P_{min} b d \Rightarrow A_{smin} = 16.90 \text{ cm}^2$$

$$P_b = 0.85 \beta_1 \frac{f_c}{f_y} \left( \frac{6000}{6000 + f_y} \right) \Rightarrow P_b = 0.02125 \Rightarrow A_{sb} = P_b b d \Rightarrow A_{sb} = 148.75 \text{ cm}^2$$

$$P_{max} = 0.75 P_b \Rightarrow P_{max} = 0.01594 \Rightarrow A_{smax} = P_{max} b d \Rightarrow A_{smax} = 111.56 \text{ cm}^2$$

$$P_d = \omega \frac{f_c}{f_y} \Rightarrow P_d = 0.00 \Rightarrow A_{sd} = P_d b d \Rightarrow A_{sd} = 7.719 \text{ cm}^2$$

$$A_{sd} < A_{smin} \Rightarrow A_{sd} = 16.90 \text{ cm}^2 \Rightarrow A_{std} = A_{sd} (L) \Rightarrow A_{std} = 62.55 \text{ cm}^2$$

$$N = \frac{A_{std}}{A_{s\phi}} \Rightarrow N = \frac{62.55}{2.84} \Rightarrow N = 22.027 \text{ UNIDADES} \Rightarrow N = 22 \text{ UNIDADES.}$$

$$S = \frac{L - 2r - \phi - 0.10}{N-1} \Rightarrow \frac{3.70 - 0.15 - 0.01905 - 0.10}{21} \Rightarrow S = 0.16 \text{ m.}$$

∞ Acero transversal: 22  $\phi 3/4 @ 0.16 \text{ m}$

DISEÑO FINAL

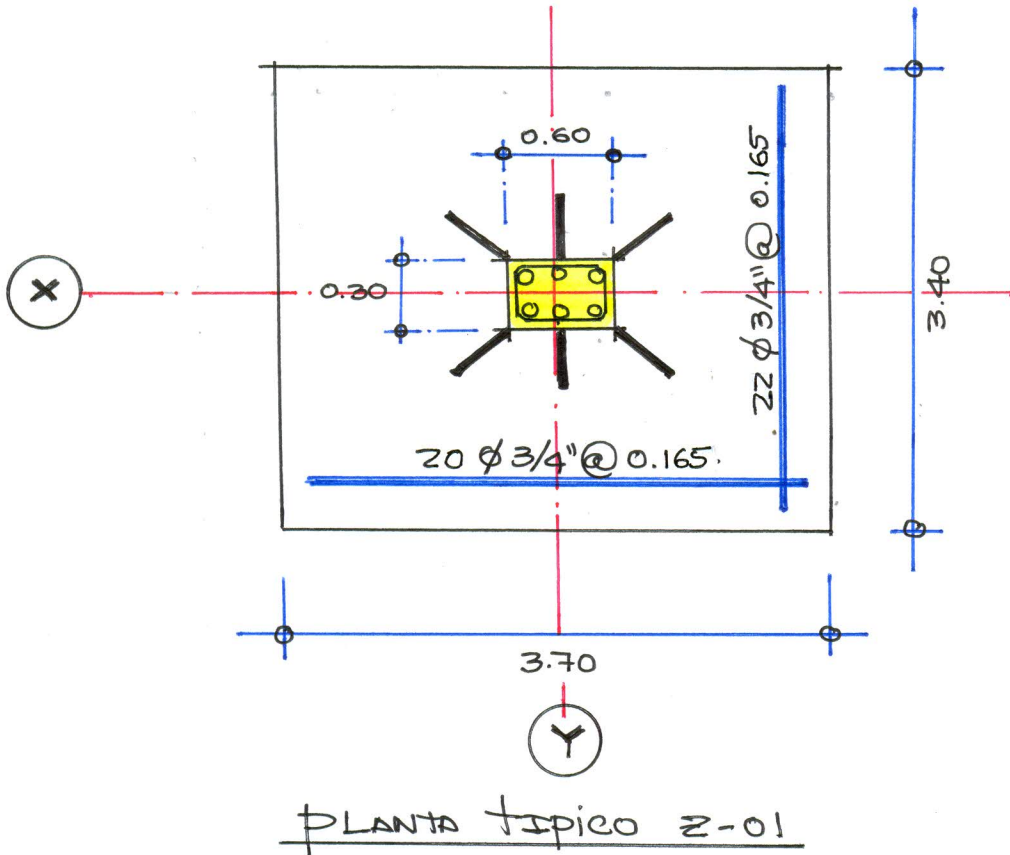
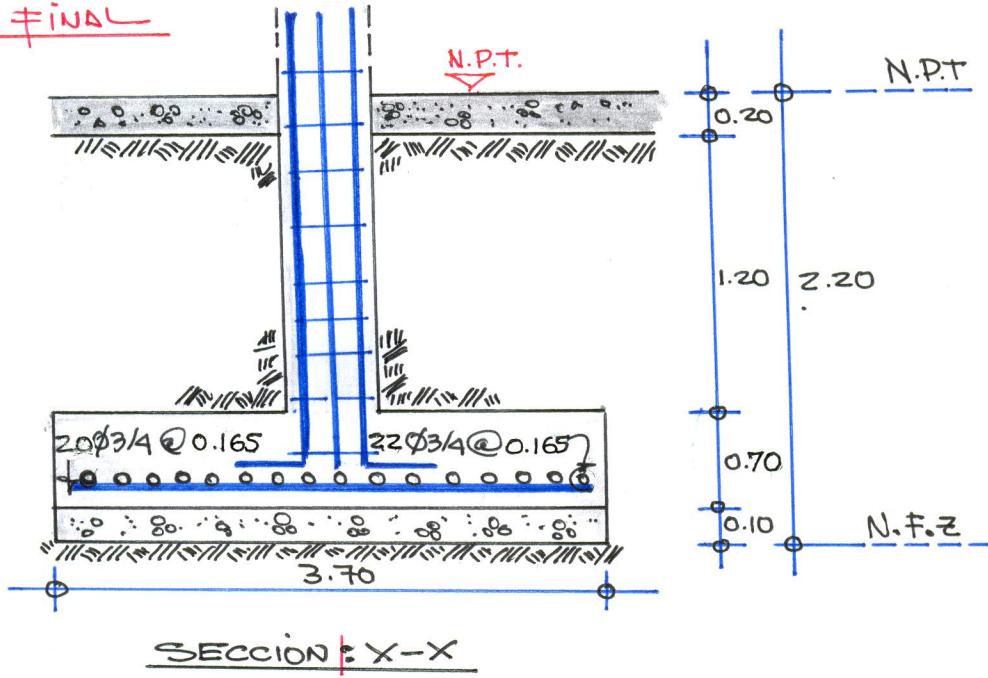

DETALLE FINAL DE ZAPATA





### PROBLEMA N° 04

DISEÑAR UNA ZAPATA AISLADA CON LAS SIGUIENTES CONSIDERACIONES TÉCNICAS Y ESTRUCTURALES.

$$P_{CH} = 125 \text{ ton}$$

$$P_{CV} = 65 \text{ ton}$$

$$P_{CS} = \phi \text{ ton}$$

$$M_{CHx} = 2.75 \text{ ton-m}$$

$$M_{CVx} = 1.65 \text{ ton-m}$$

$$M_{CSx} = 4.15 \text{ ton-m}$$

$$M_{CHy} = 2.45 \text{ ton-m}$$

$$M_{CVy} = 1.25 \text{ ton-m}$$

$$M_{CSy} = 6.55 \text{ ton-m}$$

$$f'_c = 210 \text{ kg/cm}^2$$

$$f'_y = 4200 \text{ kg/cm}^2$$

$$\gamma_s = 2.00 \text{ ton/m}^3$$

$$\gamma_{ep} = 1.80 \text{ ton/m}^3$$

$$s/c = 400 \text{ kg/m}^2$$

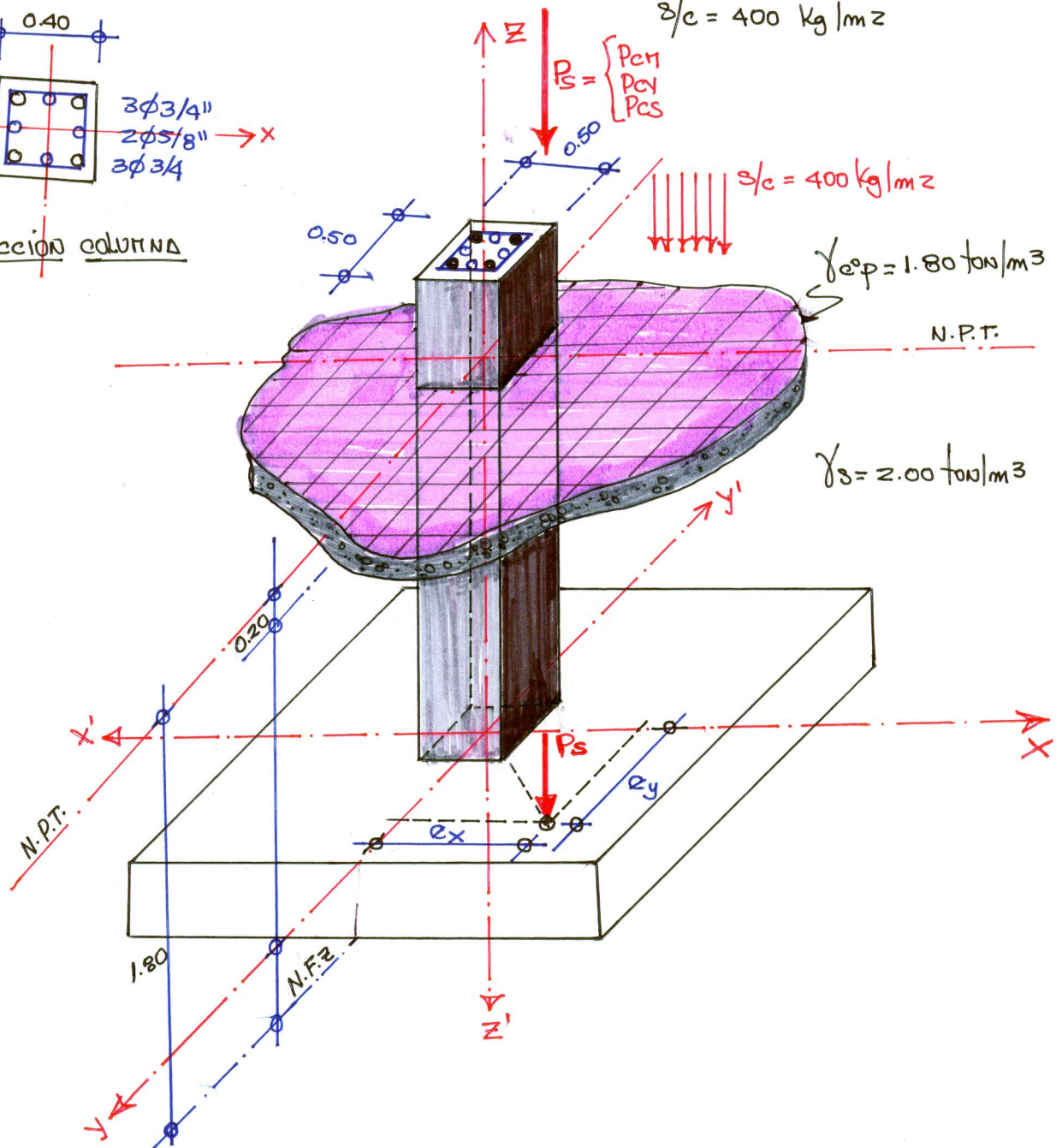
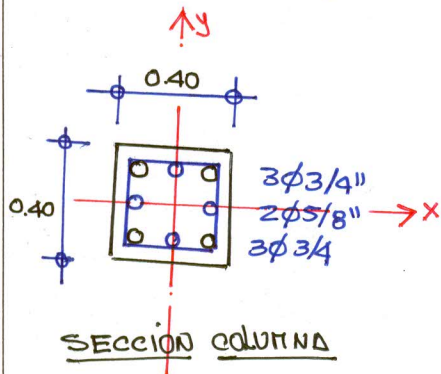

A: DIMENSIONAMIENTO DE LA ZAPATA

PERFECTE DE LA ZAPATA :  $A_s \text{ col.} : 6\phi 3/4 + 4\phi 5/8 \Rightarrow \phi 3/4$   $\left\{ \begin{array}{l} d_b = 1.905 \text{ cm.} \\ A_b = 2.84 \text{ cm}^2 \end{array} \right.$   
 CONSIDERACIONES NORMATIVAS

$$\left. \begin{array}{l} \downarrow d = 0.08 d_b f_y / \sqrt{f_c} = 44.170 \\ \downarrow d = 0.004 d_b f_y = 32.004 \\ \downarrow d \geq 20 \text{ cm.} = 20.00 \end{array} \right\} \begin{array}{l} \downarrow d = 44.17 \text{ cm.} \\ \downarrow d = 45 \text{ cm.} \end{array}$$

$$\circ d = \downarrow d + 10 \text{ cm} \Rightarrow d = 55.00 \text{ cm.} \quad h = d + 10 \text{ cm} \Rightarrow h = 65.00 \text{ cm.}$$

CAPACIDAD PORTANTE NETA DEL TERRENO ( $q_e$ )

$$q_e = C_t - (\gamma_{c2} * h_2) - (\gamma_s * h_s) - (\gamma_{cp} * h_p) - 3/c$$

$$= 25.00 - (2.40 * 0.65) - (2.00 * 0.95) - (1.80 * 0.20) - 0.40$$

$$q_e = 20.78 \text{ ton/m}^2 = 2.078 \text{ kg/cm}^2$$

AREA DE LA ZAPATA

$$\boxed{A = \frac{P_T}{q_e}} \Rightarrow A = \frac{P_{c1} + P_{c2} + P_{cs}}{q_e} \Rightarrow A = \frac{125 + 65 + 0}{20.78} \Rightarrow A = 9.143 \text{ m}^2$$

$$\circ \text{Columna F/cuadrada} \Rightarrow \text{Zapata cuadrada } B = \sqrt{A} \Rightarrow B = 3.024 \text{ m}$$

$$\circ B_x = 3.00, B_y = 3.00$$

$$A = 9.00 \text{ m}^2$$

VERIFICACION DE PRESIONES:  $\sigma_{max} < \sigma_f$   
A-1: ANALISIS ESTADICO

CARGAS DE SERVICIO:

$$P_s = P_{c1} + P_{c2} \Rightarrow P_s = 125 + 65 \Rightarrow P_s = 190.00 \text{ ton.}$$

MOMENTOS DE SERVICIO:

$$M_x = M_{cx} + M_{cy} \Rightarrow M_x = 2.75 + 1.65 \Rightarrow M_x = 4.40 \text{ ton-m.}$$

$$M_y = M_{cy} + M_{cx} \Rightarrow M_y = 2.45 + 1.25 \Rightarrow M_y = 3.70 \text{ ton-m.}$$

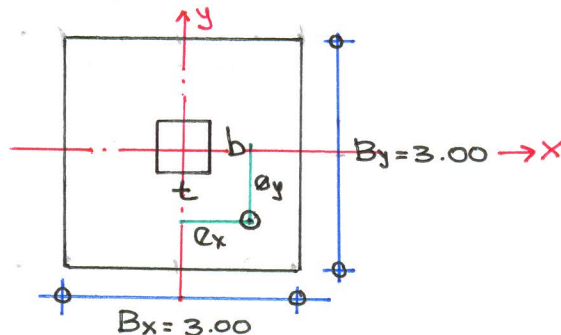



DIRECCION: X-X

$$\frac{B_x}{6} = \frac{3.00}{6} \Rightarrow \frac{B_x}{6} = 0.50 \text{ m.}$$

$$C_x = \frac{M_x}{P_s} \Rightarrow C_x = \frac{4.40}{190} \Rightarrow C_x = 0.023 \text{ m.}$$

$\Rightarrow \frac{B_x}{6} < C_x \Rightarrow$  Presión de contacto forma TRAPEZOIDAL

$$\sigma_{\text{max}} = \frac{P_s}{A} + \frac{M_x c}{I}$$

$$P_s = 190.00 \text{ ton}$$

$$A = 9.00 \text{ m}^2$$

$$M_x = 4.40 \text{ ton}\cdot\text{m}$$

$$B = 3.00 \text{ m.}$$

$$C = \frac{B_x}{2} \Rightarrow C = 1.50 \text{ m}$$

$$I = \frac{b_y b_x^3}{12} \Rightarrow I = 6.75 \text{ m}^4$$

$$\sigma_{\text{max}} = \frac{190}{9.00} + \frac{4.40(1.50)}{6.75} \Rightarrow \sigma_{\text{max}} = 22.089 \text{ ton/m}^2 < \sigma_t = 25 \text{ ton/m}^2$$

(CONFORME.)

DIRECCION: Y-Y

$$M_y = 3.70 \text{ ton}\cdot\text{m}$$

$$\frac{B_y}{6} = \frac{3.00}{6} \Rightarrow \frac{B_y}{6} = 0.50 \text{ m.}$$

$$C_y = \frac{M_y}{P_s} \Rightarrow C_y = \frac{3.70}{190} \Rightarrow C_y = 0.019 \text{ m}$$

$\Rightarrow \frac{B_y}{6} < C_y \Rightarrow$  Presión de contacto forma TRAPEZOIDAL

$$\sigma_{\text{max}} = \frac{P_s}{A} + \frac{M_y c}{I}$$

$$\sigma_{\text{max}} = \frac{190}{9.00} + \frac{3.70(1.50)}{6.75} \Rightarrow \sigma_{\text{max}} = 21.933 \text{ ton/m}^2 < \sigma_t = 25 \text{ ton/m}^2$$

(CONFORME.)

A.2: ANALISIS SISTICOCARGAS DE SERVICIO

$$P_s = P_{em} + P_{ex} + P_{cs} \Rightarrow P_s = 125 + 65 + 0 \Rightarrow P_s = 190 \text{ ton.}$$

MOMENTOS DE SERVICIO

$$M_x = M_{emx} + M_{exx} + M_{csx} \Rightarrow M_x = 2.75 + 1.65 + 4.15 \Rightarrow M_x = 8.55 \text{ ton}\cdot\text{m}$$

$$M_y = M_{emy} + M_{eyy} + M_{cyy} \Rightarrow M_y = 2.45 + 1.25 + 6.55 \Rightarrow M_y = 10.25 \text{ ton}\cdot\text{m.}$$

DIRECCION: X-X

$$C_x = \frac{M_x}{P_s} \Rightarrow C_x = \frac{8.55}{190} \Rightarrow C_x = 0.045 \quad \frac{B_x}{6} = 0.50$$

Presión de contacto forma TRAPEZOIDAL

$$\sigma_{\text{max}} = \frac{P_s}{A} + \frac{M_x c}{I}$$

$$\sigma_{\text{max}} = \frac{190}{9.00} + \frac{8.55(1.50)}{6.75} \Rightarrow \sigma_{\text{max}} = 23.011 \text{ ton/m}^2 < \sigma_t$$

(CONFORME.)



DIRECCION: Y-Y

$Q_y = \frac{M_y}{P_s} \Rightarrow Q_y = \frac{10.25}{190.00} \Rightarrow Q_y = 0.054 < \frac{1}{6}$  PRESION DE CONTACTO FORJA TRAPEZOIDAL

$\sigma_{MAX} = \frac{P_s}{A} + \frac{M_y(c)}{I}$

$\sigma_{MAX} = \frac{190}{9.00} + \frac{10.25(1.50)}{6.75} \Rightarrow \sigma_{MAX} = 23.389 \text{ ton/m}^2 < G_9 = 25 \text{ ton/m}^2$   
(CONFORME)

CARGAS DE DISEÑO: (Pu, Mw)

REACCION AMPLIFICADA DEL SUELO:

ANALISIS ESTADICO:

$P_u = 1.40 P_{CH} + 1.70 P_{CV} \Rightarrow P_u = 1.40(125) + 1.70(65) \Rightarrow P_u = 285.50 \text{ ton.}$

$M_{Wx} = 1.40 M_{CHx} + 1.70 M_{CVx} \Rightarrow M_{Wx} = 1.40(2.75) + 1.70(1.65) \Rightarrow M_{Wx} = 6.655 \text{ ton-m}$

$M_{Wy} = 1.40 M_{CHy} + 1.70 M_{CVy} \Rightarrow M_{Wy} = 1.40(2.45) + 1.70(1.25) \Rightarrow M_{Wy} = 5.555 \text{ ton-m}$

DIRECCION: X-X  $\frac{B_x}{6} = \frac{B_y}{6} = 0.50$

$Q_x = \frac{M_{Wx}}{P_u} \Rightarrow Q_x = \frac{6.655}{285.50} \Rightarrow Q_x = 0.023 < \frac{B_x}{6}$   
(CONFORME)

$\sigma_{X(1,2)} = \frac{P_u}{A} \pm \frac{M_{Wx}(c)}{I} = \frac{285}{9.00} \pm \frac{6.655(1.50)}{6.75}$

$\sigma_{X(1,2)} \begin{cases} \sigma_{X1} = 33.201 \text{ ton/m}^2 \\ \sigma_{X2} = 30.243 \text{ ton/m}^2 \end{cases}$

DIRECCION: Y-Y

$Q_y = \frac{M_{Wy}}{P_u} = \frac{5.555}{285.5} \Rightarrow Q_y = 0.019 < \frac{B_y}{6}$   
(CONFORME)

$\sigma_{Y(1,2)} = \frac{P_u}{A} \pm \frac{M_{Wy}(c)}{I} = \frac{285}{9.00} \pm \frac{5.555(1.50)}{6.75}$

$\sigma_{Y(1,2)} \begin{cases} \sigma_{Y1} = 32.957 \text{ ton/m}^2 \\ \sigma_{Y2} = 30.488 \text{ ton/m}^2 \end{cases}$

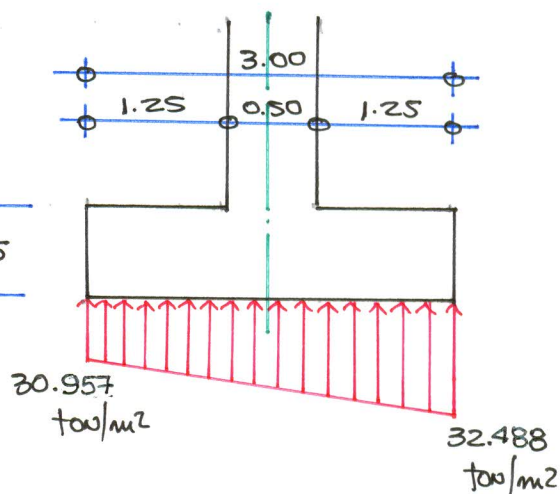
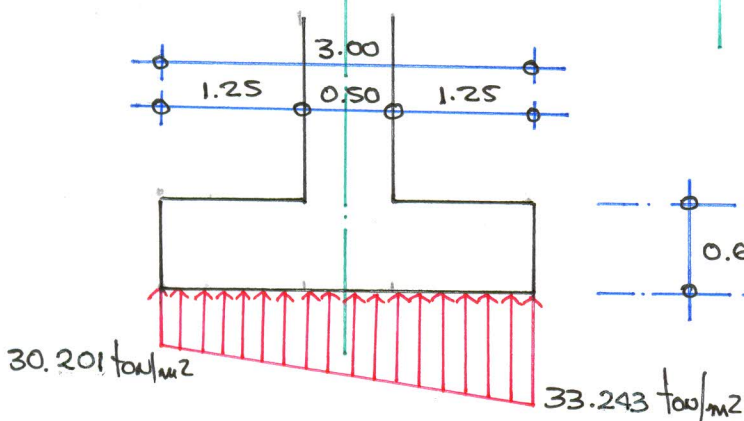

ANÁLISIS SISTÉMICO:

$$P_{CH} = 125 \text{ ton}$$

$$P_{CV} = 65 \text{ ton}$$

$$P_{CS} = \emptyset$$

$$M_{CHX} = 2.75 \text{ ton-m}$$

$$M_{CVX} = 1.65 \text{ ton-m}$$

$$M_{CSX} = 4.65 \text{ ton-m}$$

$$M_{CHY} = 2.45 \text{ ton-m}$$

$$M_{CVY} = 1.25 \text{ ton-m}$$

$$M_{CSY} = 6.55 \text{ ton-m}$$

COMBINACIONES DE CARGA:

$$U = 1.25(CH + CV) \pm CS$$

$$U = 0.90CH \pm CS$$

DIRECCION: X-X

$$P_U: \begin{cases} P_U = 1.25(125 + 65) + 0 \Rightarrow P_U = 237.50 \text{ ton} \checkmark \\ P_U = 0.90(125) + 0 \Rightarrow P_U = 112.50 \text{ ton} \end{cases}$$

$$M_{UX}: \begin{cases} M_{UX} = 1.25(2.75 + 1.65) + 4.65 \Rightarrow M_{UX} = 10.15 \text{ ton-m} \checkmark \\ M_{UX} = 0.90(2.75) + 4.65 \Rightarrow M_{UX} = 7.125 \text{ ton-m} \end{cases}$$

$$\sigma_{x1,2} = \frac{P_U}{A} \pm \frac{M_{UX} c}{I}$$

$$\sigma_{x1,2} \begin{cases} \sigma_{x1} = 28.64 \text{ ton/m}^2 \\ \sigma_{x2} = 24.13 \text{ ton/m}^2 \end{cases}$$

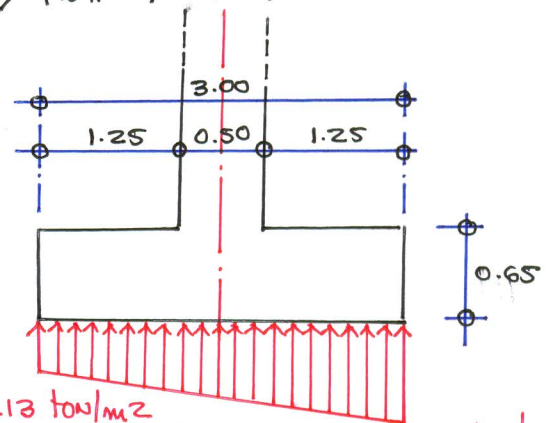
DIRECCION: Y-Y

$$P_U = \begin{cases} P_U = 1.25(125 + 65) + 0 \Rightarrow P_U = 237.50 \text{ ton} \checkmark \\ P_U = 0.90(125) + 0 \Rightarrow P_U = 112.50 \text{ ton} \end{cases}$$

$$M_{UY} = \begin{cases} M_{UY} = 1.25(2.45 + 1.25) + 6.55 \Rightarrow M_{UY} = 11.175 \text{ ton-m} \checkmark \\ M_{UY} = 0.90(2.45) + 6.55 \Rightarrow M_{UY} = 8.755 \text{ ton-m} \end{cases}$$

$$\sigma_{y1,2} = \frac{P_U}{A} \pm \frac{M_{UY} c}{I}$$

$$\sigma_{y1,2} \begin{cases} \sigma_{y1} = 28.87 \text{ ton/m}^2 \\ \sigma_{y2} = 23.91 \text{ ton/m}^2 \end{cases}$$

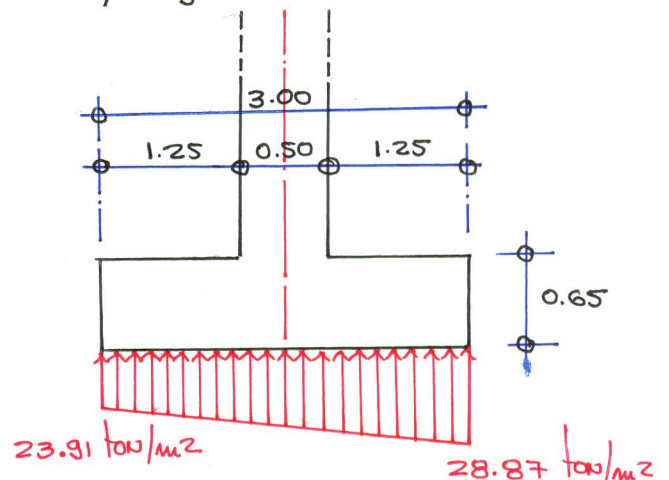





# RESUMEN DE PRESIONES (Estático - Sísmico)

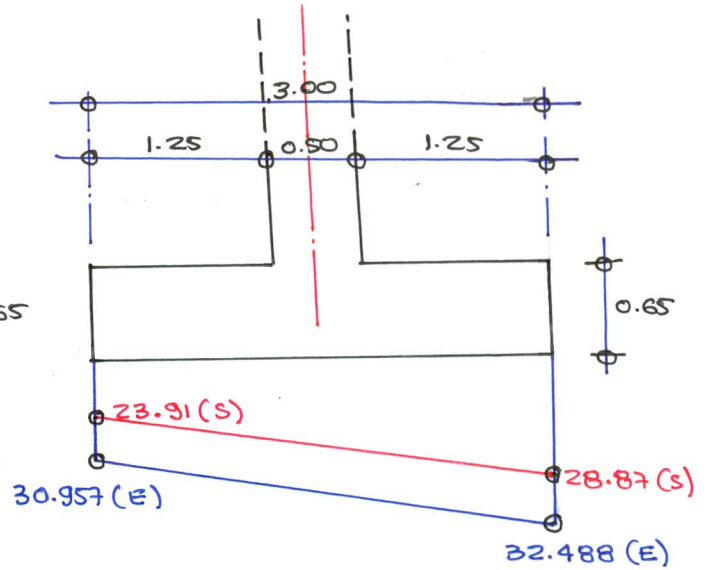
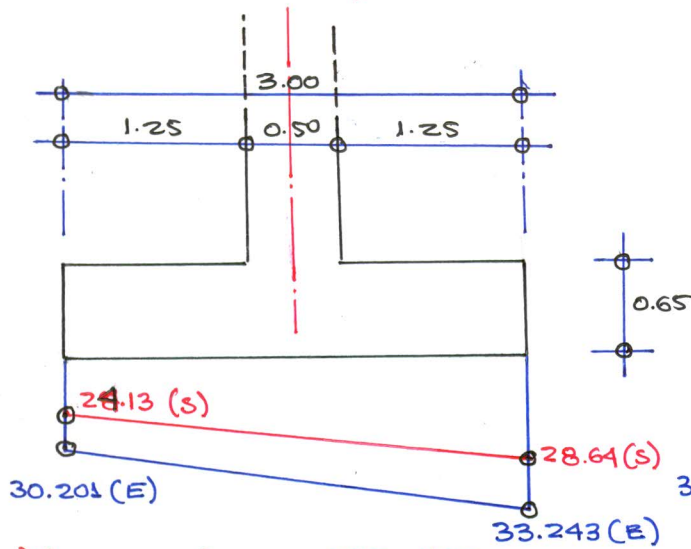

## VERIFICACION CORTE-FLEXION

### DIRECCION X-X

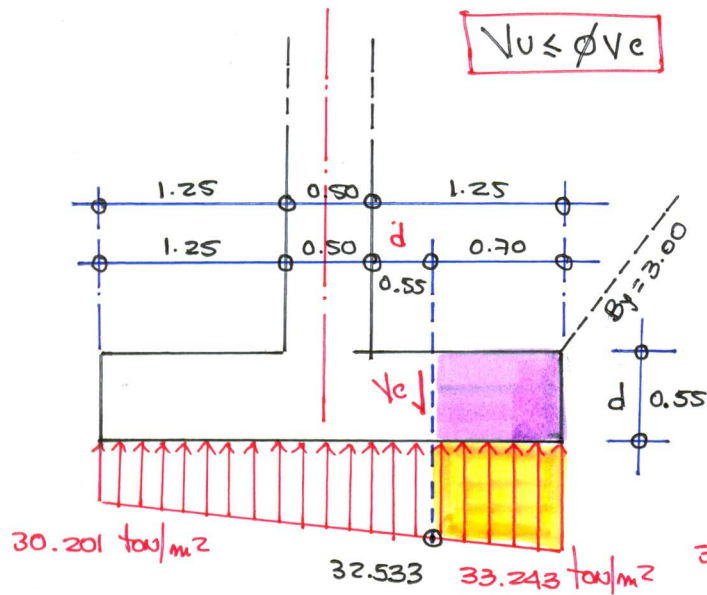

$$V_u = \left[ \frac{(33.243 + 32.533) \cdot 0.70}{2} \right] \cdot 3.00$$

$$V_u = 69.065 \text{ ton} = 69064.800 \text{ kg}$$

$$\phi V_c = \phi \cdot 0.53 \cdot \sqrt{f_c} \cdot B_y \cdot d$$

$$\phi V_c = 0.85 \cdot 0.53 \cdot \sqrt{210} \cdot 300 \cdot 55$$

$$\phi V_c = 107.718 \text{ ton} = 107718.00 \text{ kg}$$

CONFORME:  $V_u < \phi V_c$

### DIRECCION Y-Y

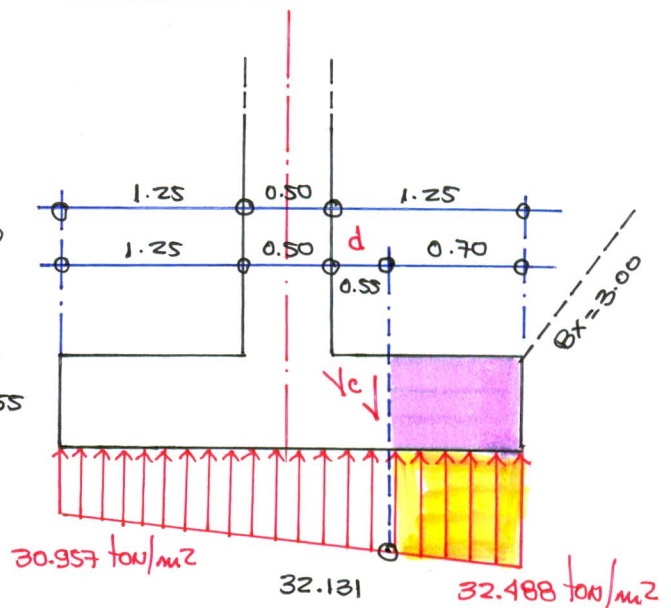

$$V_u = \left[ \frac{(32.488 + 32.131) \cdot 0.70}{2} \right] \cdot 3.00$$

$$V_u = 67.850 \text{ ton} = 67849.95 \text{ kg}$$

$$\phi V_c = \phi \cdot 0.53 \cdot \sqrt{f_c} \cdot B_x \cdot d$$

$$\phi V_c = 0.85 \cdot 0.53 \cdot \sqrt{210} \cdot 300 \cdot 55$$

$$\phi V_c = 107.718 \text{ ton} = 107718.00 \text{ kg}$$

CONFORME:  $V_u < \phi V_c$



VERIFICACIÓN POR FUNZIONAMIENTO:

$$b_0 = 4(1.05) \Rightarrow b = 420 \text{ cm}$$

$$\beta_0 = \frac{0.50}{0.50} \Rightarrow \beta_0 = 1$$

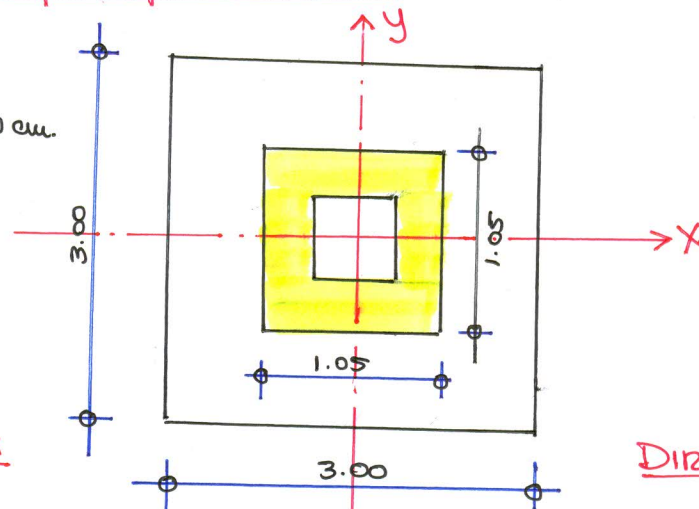
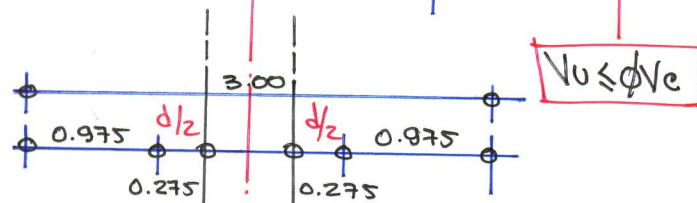
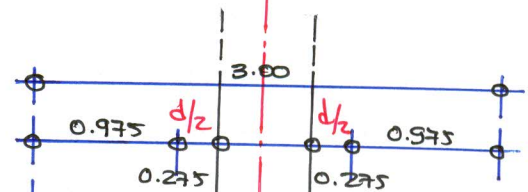
DIRECCIÓN: X-XDIRECCIÓN: Y-Y

$$V_u \leq \phi V_c$$

$$d = 0.55$$

30.201 ton/m<sup>2</sup>    31.190    32.254    33.243 ton/m<sup>2</sup>

20.957 ton/m<sup>2</sup>    31.455    31.990    32.488 ton/m<sup>2</sup>

DIRECCIÓN: X-X

$$V_{u_x} = \left[ \frac{(33.243 + 30.201) \cdot 3.00}{2} \right] \cdot 3.00 - \left[ \frac{(32.254 + 31.190) \cdot 1.05}{2} \right] \cdot 1.05$$

$$V_u = 250.524 \text{ ton} = 250\,524.495 \text{ kg}$$

$$\phi V_c = \phi \left( 0.53 + \frac{1.10}{\beta_0} \right) \sqrt{f_c} b_0 d$$

$$\phi V_c = 0.85 \left( 0.53 + \frac{1.10}{1} \right) \sqrt{210} \cdot 420 \cdot 55 \Rightarrow \phi V_c = 463.797 \text{ ton} = 463\,797.237 \text{ kg}$$

DIRECCIÓN: Y-Y

$$V_u = \left[ \frac{(32.488 + 20.957) \cdot 3.00}{2} \right] \cdot 3.00 - \left[ \frac{(31.990 + 31.455) \cdot 1.05}{2} \right] \cdot 1.05$$

$$V_{u_y} = 250.528 \text{ ton} = 250\,528.444 \text{ kg}$$

∴  $V_{u_x}, V_{u_y} < \phi V_c \Rightarrow$  CONFORME

# DISEÑO DE REFUERZO POR FLEXIÓN

$f_c = 210 \text{ kg/cm}^2$   
 $f_y = 4200 \text{ kg/cm}^2$

DIRECCIÓN: X-X

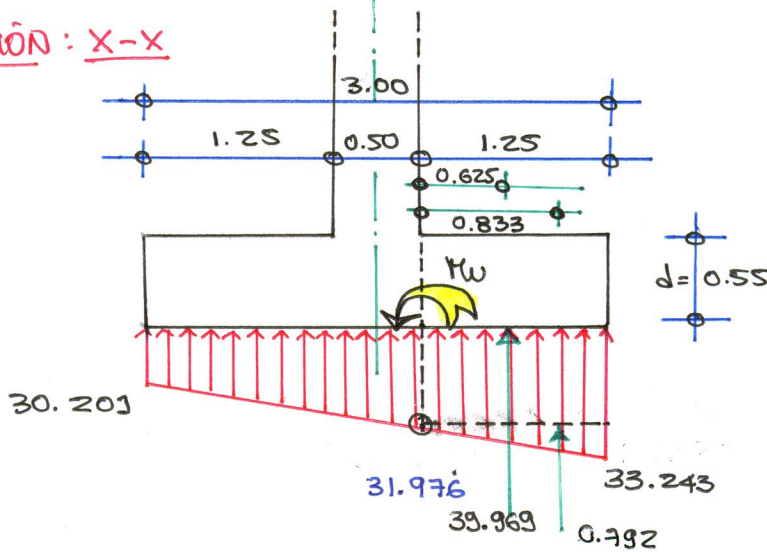

$M_w = 39.969 (0.625) + 0.792 (0.833) \Rightarrow M_w = 25.640 \text{ ton-m}$

DATOS DE DISEÑO:  $M_w = 26.135 \text{ ton-m}$ .  $b = 100 \text{ cm}$ .  $d = 55 \text{ cm}$ ,  $f_c = 210 \text{ kg/cm}^2$ ,  $f_y = 4200 \text{ kg/cm}^2$

$\alpha = \frac{A_s f_y}{0.85 f_c b}$

$M_w = \phi A_s f_y (d - a/2)$

$\rho_{min} = 0.70 \sqrt{f_c} / f_y \Rightarrow \rho_{min} = 0.00242 \Rightarrow A_s = \rho_{min} b d \Rightarrow A_{smin} = 13.284 \text{ cm}^2$

$\rho_b = 0.85 \beta \frac{f_c}{f_y} \left( \frac{6000}{6000 + f_y} \right) \Rightarrow \rho_b = 0.02125 \Rightarrow A_{sb} = \rho_b b d \Rightarrow A_{sb} = 116.875$

$\rho_{max} = 0.50 \rho_b \Rightarrow \rho_{max} = 0.01063 \Rightarrow A_{smax} = \rho_{max} b d \Rightarrow A_{smax} = 58.465$

$\rho_d = \frac{w f_c}{f_y} \Rightarrow \rho_d = 0.00231 \Rightarrow A_{sd} = \rho_d b d \Rightarrow A_{sd} = 12.677 \text{ cm}^2$

$A_s \phi 5/8$ :  $d_b \phi 5/8 = 1.588 \text{ cm} \Rightarrow \phi 5/8 = 2.00 \text{ cm}^2$   
 0.016 m.

# DE VARILLAS:  $A_{std} = A_{sd} \times B_y = 13.284 (3.00) \Rightarrow A_{std} = 39.852 \text{ cm}^2$

$N = \frac{A_{std}}{A_\phi} \Rightarrow N = \frac{39.852}{2.00} \Rightarrow N = 20 \text{ UNIDADES}$

## DISTRIBUCIÓN DE ACERO

$S = \frac{B_x - 2r - \phi - 0.10}{N - 1} \Rightarrow S = \frac{3.00 - 0.015 - 1.588 - 0.10}{19} \Rightarrow S = 144 \text{ mm} \sim 0.15$

19  $\phi 5/8$  @ 0.15

DIRECCION : Y-Y

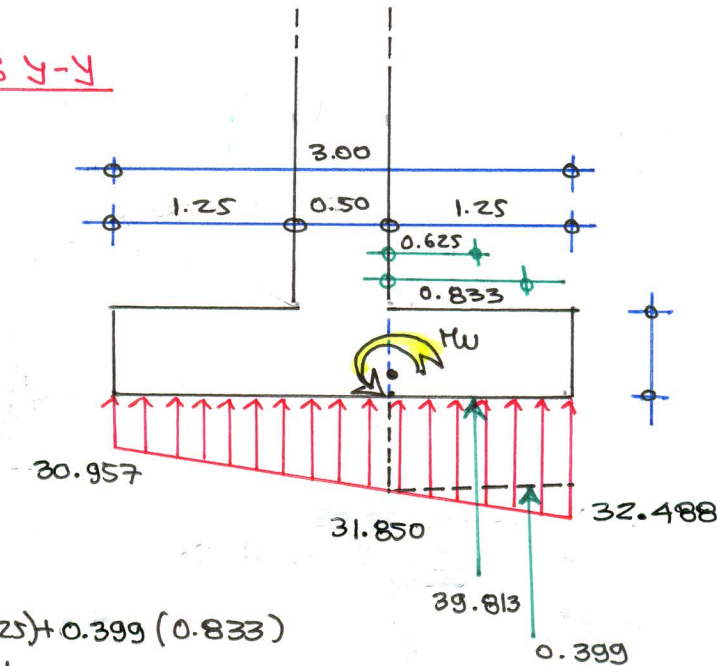

$$w = 39.813(0.625) + 0.399(0.833)$$

$$w = 25.215 \text{ ton-m.}$$

DATOS :  $w = 26.37 \text{ ton-m}$ ,  $b = 100 \text{ cm}$ ,  $d = 55 \text{ cm}$ ,  $f_c = 210 \text{ kg/cm}^2$ ,  $f_y = 4200 \text{ kg/cm}^2$

$$\rho_{\min} = 0.70 \sqrt{f_c} / f_y \Rightarrow \rho_{\min} = 0.00242 \quad A_{s\min} = 13.284 \text{ cm}^2$$

$$\rho_b = 0.85 \beta_1 \frac{f_c}{f_y} \left( \frac{6000}{6000 + f_y} \right) \Rightarrow \rho_b = 0.02125 \quad A_{sb} = 116.875 \text{ cm}^2$$

$$\rho_d = w \frac{f_c}{f_y} \Rightarrow \rho_d = 0.00227 \quad A_{sd} = 12.462 \text{ cm}^2$$

$$\rho_{\max} = 0.50 \rho_b \Rightarrow \rho_{\max} = 0.01063 \quad A_{s\max} = 58.4375 \text{ cm}^2$$

$$A_{s\phi 5/8} = 2.00 \text{ cm}^2 \quad d_b = 0.016 \text{ cm.}$$

# VARILLAS :  $A_{std} = A_{sd} (B_x) \Rightarrow A_{std} = (13.284)(3) \Rightarrow A_{std} = 39.852 \text{ cm}^2$

$$N = \frac{A_{std}}{A_{\phi}} = \frac{39.852}{2.00} \Rightarrow N = 20 \text{ varillas}$$

ESPACIAMIENTO DE ACEROS

$$s = \frac{B_x - 2r - \phi - 0.10}{N-1} = \frac{3.00 - 0.15 - 0.016 - 0.10}{19} \Rightarrow s = 0.145 \text{ m.}$$

20  $\phi 5/8'' @ 0.145$

DETALLE EN PLANTA

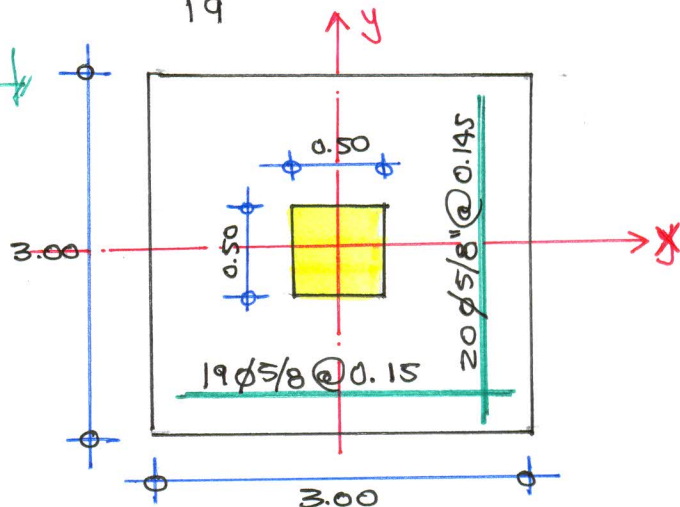



PROBLEMA N° 05 :

DIMENSIONAR, VERIFICAR, DISEÑAR LA ZAPATA EXCÉNTRICA DE LA FIGURA ADJUNTA, PARA LAS SOLICITACIONES QUE SE INDICAN.

$P_{CH} = 32 \text{ ton}$        $M_D = M_{CH} = 6.00 \text{ ton-m}$        $f_c = 210 \text{ kg/cm}^2$   
 $P_{CV} = 12 \text{ ton}$        $M_{CV} = 4.00 \text{ ton-m}$        $f_y = 4200 \text{ kg/cm}^2$   
 $\leftarrow t = 2.00 \text{ kg/cm}^2$

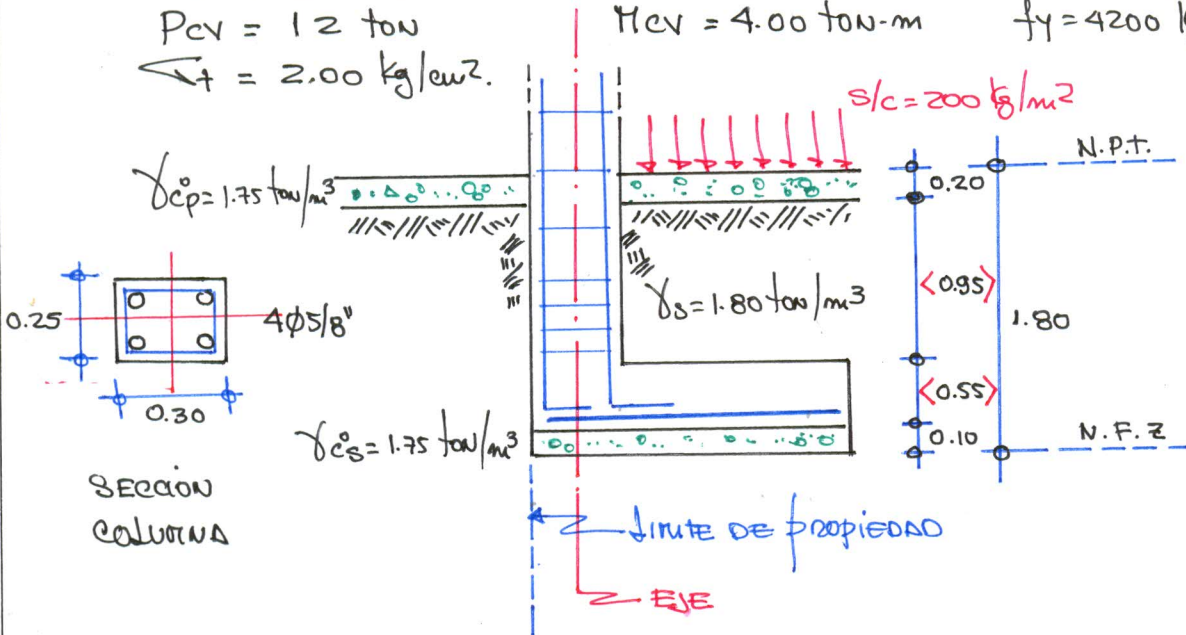

DIMENSIONAMIENTO :

- PERALTE :  $A_{scol} = 4\phi 5/8" \Rightarrow \phi 5/8" \left\{ d_b = 1.588 \text{ cm}, A_b = 2.00 \text{ cm}^2 \right.$   
CONSIDERACION NORMATIVAS

$l_d = 0.08 d_b f_y / \sqrt{f_c} \Rightarrow l_d = 36.82 \text{ cm}$        $l_d = 36.82 \text{ cm}$   
 $l_d = 0.004 d_b f_y \Rightarrow l_d = 26.678 \text{ cm} \Rightarrow$   
 $l_d \geq 20 \text{ cm} \Rightarrow l_d = 20 \text{ cm}$        $l_d = 35 \text{ cm} \checkmark$

$\circ \circ d = l_d + 10 \text{ cm} \Rightarrow d = 45 \text{ cm} \Rightarrow h = d + 10 \text{ cm} \Rightarrow h = 55 \text{ cm}$

- CAPACIDAD PORTANTE NETA DEL TERRENO (q<sub>e</sub>)

$q_e = \gamma - (\gamma_{cs} \times h_s) - (\gamma_{cz} \times h_z) - (\gamma_s \times h_s) - (\gamma_{cp} \times h_p) - s/c$   
 $q_e = 20.00 - (1.75 \times 0.10) - (2.40 \times 0.55) - (1.80 \times 0.95) - (1.75 \times 0.20) - 0.20$   
 $q_e = 16.245 \text{ ton/m}^2 = 1.6245 \text{ kg/cm}^2$

SOLICITACIONES :

↳ CARGAS DE SERVICIO :  $P_s = P_{cm} + P_{cv} \Rightarrow P_s = 32 + 12 \Rightarrow P_s = 44.00 \text{ ton.}$   
 $M_s = M_{cm} + M_{cv} \Rightarrow M_s = 6 + 4 \Rightarrow M_s = 10.00 \text{ ton-m.}$

↳ CARGAS ULTIMAS :  $P_u = 1.40 P_{cm} + 1.70 P_{cv} \Rightarrow P_u = 1.40(32) + 1.70(12) \Rightarrow P_u = 65.20 \text{ ton}$   
 $M_u = 1.40 M_{cm} + 1.70 M_{cv} \Rightarrow M_u = 1.40(6) + 1.70(4) \Rightarrow M_u = 15.20 \text{ ton-m.}$

ZAPATAS SIN EXCENTRICIDAD

$$\boxed{A = \frac{P_s}{q_e}} \Rightarrow A = \frac{44.00}{1.625} \Rightarrow A = 2.709 \text{ m}^2$$

∴ TENDER ZAPATA EXCENTRICIDAD  $A > 2.709 \text{ m}^2$

EXCENTRICIDAD  $\Rightarrow e = \frac{M_s}{P_s} \Rightarrow e = \frac{10.00}{44.00} \Rightarrow e = 0.227 \text{ m.}$

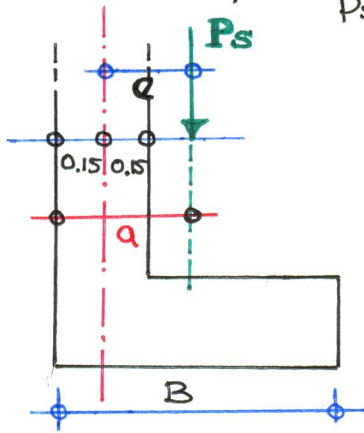

$$B_{\min} = 3e \Rightarrow B_{\min} = 0.681 \text{ m}$$

$$B_{\max} = 2a \Rightarrow B_{\max} = 0.754 \text{ m.}$$

$$BL = A \quad : \quad L = 2B \quad : \quad B = \sqrt{\frac{A}{2}}$$

$$B = \sqrt{\frac{2.709}{2}} \Rightarrow B = 1.164 \sim B = 1.20 \text{ m.}$$

∴  $B = 1.20$  ,  $L = 2.40 \Rightarrow A = 2.88 \text{ m}^2$

VERIFICACIÓN DE PRESIÓN  $\sigma_{\max} < \sigma_f$ 

$$\left. \begin{array}{l} B = 1.20 \text{ m} \\ L = 2.40 \text{ m} \\ A = 2.88 \text{ m}^2 \\ I = 0.346 \text{ m}^4 \\ c = 0.60 \text{ m.} \end{array} \right\}$$

$$\sigma_{\max} = \frac{P_s}{A} + \frac{M_s c}{I} = \frac{44.00}{2.88} + \frac{10(0.60)}{0.346} \Rightarrow \sigma_{\max} = 32.619 \text{ ton/m}^2 > \sigma_f$$

(NO CUMPLE)  
REDIMENSIONAR AREA

$$\left. \begin{array}{l} B = 1.50 \text{ m} \\ L = 3.00 \text{ m} \\ A = 4.50 \text{ m}^2 \\ I = 0.844 \\ c = 0.75 \text{ m.} \end{array} \right\}$$

$$\sigma_{\max} = \frac{44.00}{4.50} + \frac{10(0.75)}{0.844} \Rightarrow \sigma_{\max} = 18.664 < \sigma_f$$

(CUMPLE)

CARGAS DE DISEÑO (Pu, Mw) Pu = 65.20 ton Mw = 15.20 ton-m.

REACCION AMPLIFICADA DEL SUELO :

$$Q_u = M_w/P_u \Rightarrow Q_u = 15.20/65.20 \Rightarrow Q_u = 0.233 < B/6 = 0.25 \text{ m}$$

PRESION DE CONTACTO F/TRAPEZOIDAL

$$\sigma_{1,2} = \frac{P_u}{A} \pm \frac{M_w(c)}{I}$$

$$\sigma_{1,2} = \frac{65.20}{4.50} \pm \frac{15.20(0.75)}{0.844}$$

$$\sigma_1 = 27.996 \text{ ton/m}^2$$

$$\sigma_2 = 0.982 \text{ ton/m}^2$$

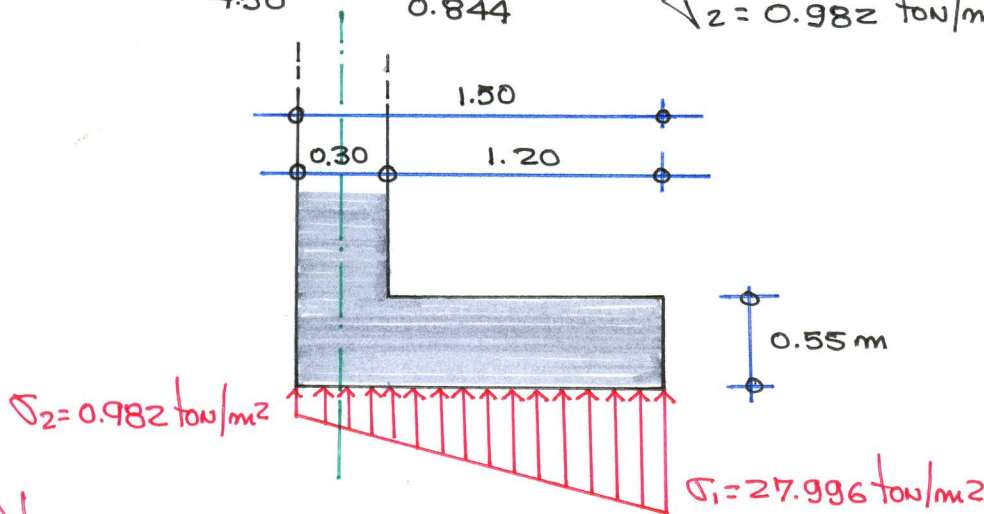

VERIFICACION POR CORTANTE :

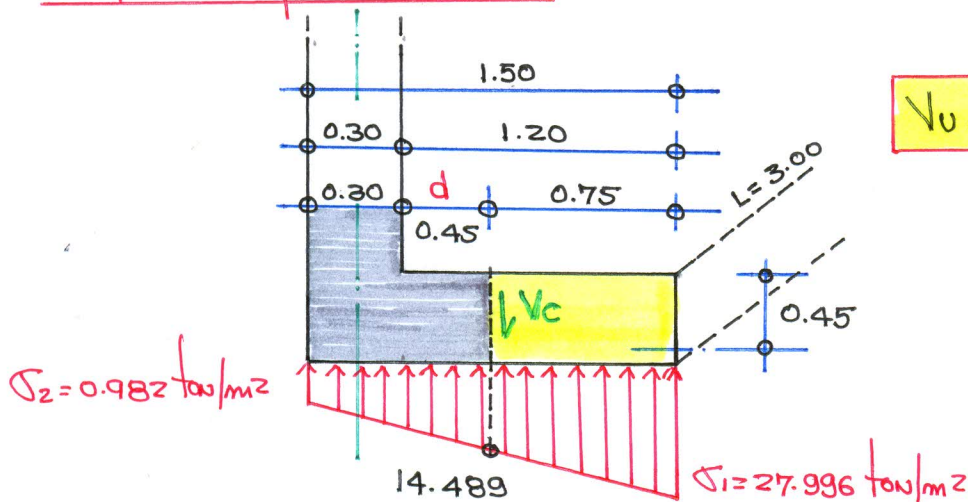

$$V_u \leq \phi V_c$$

$$V_u = \left[ \frac{(27.996 + 14.489) \cdot 0.75 \cdot (3.00)}{2} \right] \Rightarrow V_u = 47.796 \text{ ton} = 47795.625 \text{ kg}$$

$$\phi V_c = \phi \cdot 0.53 \sqrt{f_c} \cdot L \cdot d \Rightarrow \phi V_c = 0.85 \cdot 0.53 \sqrt{210} \cdot 300 \cdot 45 \Rightarrow \phi V_c = 88.133 \text{ ton}$$

$$\circ \circ V_u = 47.796 \text{ ton} < \phi V_c = 88.133 \Rightarrow \text{(CONFORME)}$$

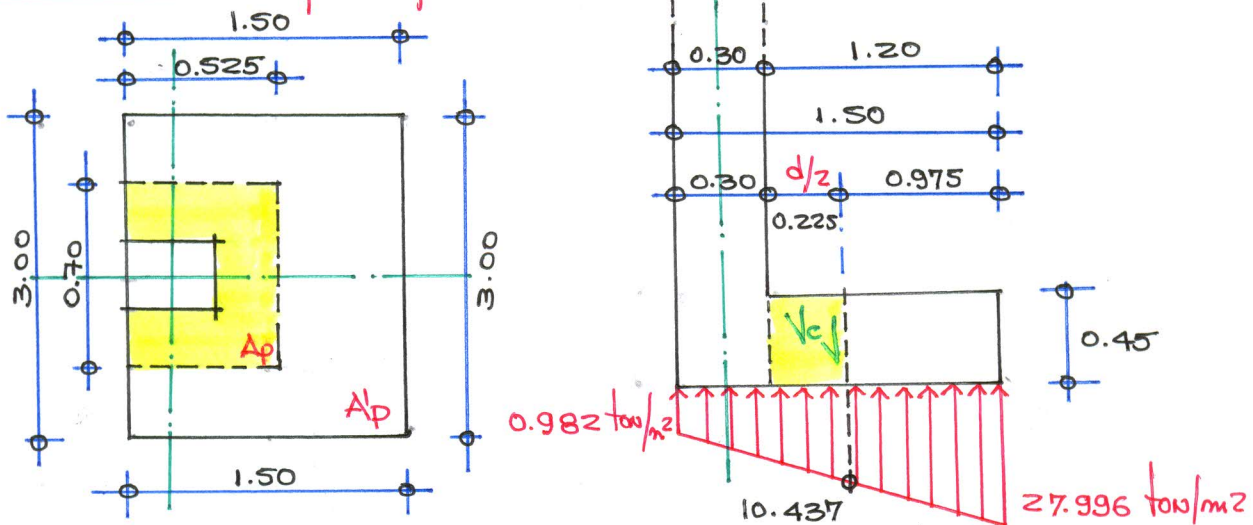

VERIFICACION POR PUNZONAMIENTO:

PERIMETRO DE PUNZONAMIENTO

$$b_0 = 2(0.525) + 0.70 \Rightarrow b_0 = 1.75 \text{ m.}$$

RELACION DE LADOS DE LA COLUMNA

$$\beta_0 = \frac{\text{LADO MAYOR}}{\text{LADO MENOR}} \Rightarrow \beta_0 = \frac{30}{25} \Rightarrow \beta_0 = 1.20$$

$$V_u \leq \phi V_c$$

$$V_u = \left[ \frac{(27.996 + 0.982) 1.50 (3.00)}{2} \right] - \left[ \frac{(10.437 + 0.982) 0.525 (0.70)}{2} \right]$$

$$V_u = 63.102 \text{ ton} = 63\,102.259 \text{ kg}$$

$$\phi V_c = \phi \left( 0.53 + \frac{1.10}{\beta_0} \right) \sqrt{f_c} b_0 d$$

$$= 0.85 \left( 0.53 + \frac{1.10}{1.20} \right) \sqrt{210} * 175 * 45$$

$$\phi V_c = 140\,329.058 \text{ kg} = 140.329 \text{ ton.}$$

$$\phi V_c = 140.329 \text{ ton} > V_u = 63.102 \text{ ton}$$

(CONFORME)

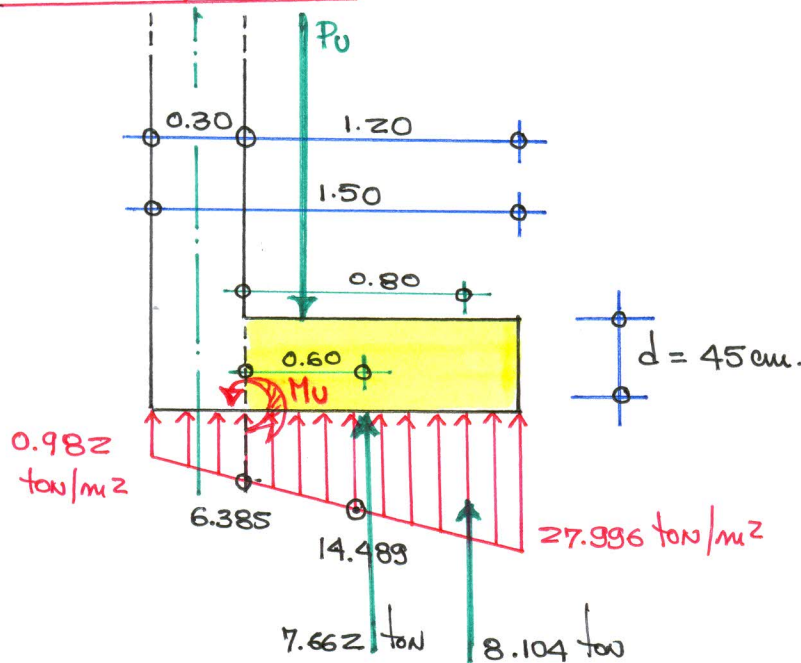
DISEÑO DE REFUERZODISEÑO DE REFUERZO LONGITUDINAL

$$l_u = 11.080 \text{ ton-m}, \quad b = 100 \text{ cm}, \quad d = 45 \text{ cm}, \quad f_c = 210 \text{ kg/cm}^2, \quad f_y = 4200 \text{ kg/cm}^2$$

$$\rho_{min} = 0.70 \sqrt{f_c} / f_y \Rightarrow \rho_{min} = 0.00242 \Rightarrow A_{smin} = \rho_{min} b d \Rightarrow A_{smin} = 10.868 \text{ cm}^2$$

$$\rho_b = 0.85 \beta \frac{f_c}{f_y} \left( \frac{6000}{6000 + f_y} \right) \quad \rho_b = 0.02125 \Rightarrow A_{sb} = \rho_b b d \Rightarrow A_{sb} = 95.625 \text{ cm}^2$$

$$\rho_{max} = 0.75 \rho_b \quad \rho_{max} = 0.01594 \Rightarrow A_{smax} = \rho_{max} b d \Rightarrow A_{smax} = 71.719 \text{ cm}^2$$

$$\rho_{dis} = \omega \frac{f_c}{f_y} \quad \rho_{dis} = 0.00147 \Rightarrow A_{sd} = \rho_{dis} b d \Rightarrow A_{sd} = 6.629 \text{ cm}^2$$

$$\# \text{ barras } N = \frac{A_{st}}{A_{s\phi}} \quad \phi 5/8 = 2.00 \text{ cm}^2 \quad A_{st} = 32.604 \text{ cm}^2$$

$$N = \frac{32.604}{2.00} \Rightarrow N = 16.302 \sim \underline{N = 16 \text{ UNIDADES.}}$$

Distribución:

$$S = \frac{3.00 - 0.15 - 0.01588 - 0.10}{15} \Rightarrow \underline{S = 0.18 \text{ m.}}$$

$$\underline{16 \phi 5/8 @ 0.18}$$

DISEÑO DE REFUERZO TRANSVERSAL

$$M_w = \frac{14.489 (1.375)^2}{2} \Rightarrow M_w = 13.697 \text{ ton-m.}$$

$$b = 100 \text{ cm}, d = 45.00 \text{ cm}, f_c = 210 \text{ kg/cm}^2, f_y = 4200 \text{ kg/cm}^2$$

$$\rho_{\min} = 0.00242$$

$$A_{st\min} = 10.868 \text{ cm}^2$$

$$\rho_b = 0.02125$$

$$A_{sb} = 95.625 \text{ cm}^2$$

$$\rho_{\max} = 0.01594$$

$$A_{s\max} = 71.718 \text{ cm}^2$$

$$\rho_{dis} = 0.00183$$

$$A_{sd} = 8.23 \text{ cm}^2$$

∴ ACERO DE DISEÑO TRANSVERSAL  $A_{sd} = 10.868 \text{ cm}^2$

$$\# \text{ DE ACEROS : } A_{st} = 10.868 (1.50) \Rightarrow A_{st} = 16.302 \quad A_{sq} \frac{5}{8} = 2.00$$

$$N = \frac{A_{st} d}{A_{sq}} \Rightarrow N = \frac{16.302}{2.00} \Rightarrow N = 8.15 \sim \underline{N = 8 \text{ UNIDADES}}$$

1) DISTRIBUCION DE ACEROS (s)

$$S = \frac{1.50 - 0.15 - 0.01588 - 0.10}{7} \Rightarrow \underline{S = 0.176 \text{ m.}}$$

ACERO TRANSVERSAL :  $8 \phi 5/8 @ 0.176 \text{ m.} \sim 8 \phi 5/8 @ 0.18$

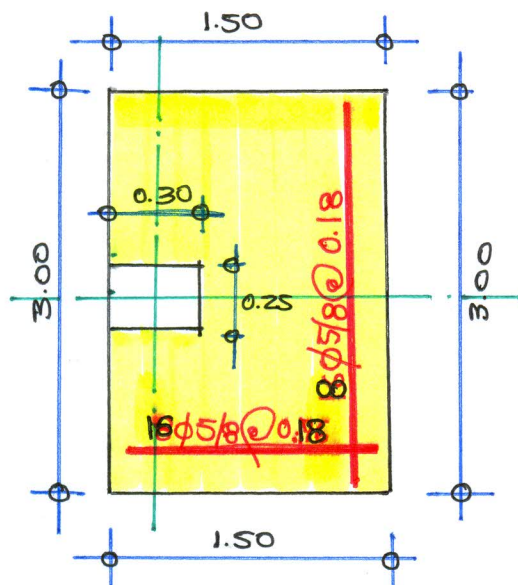

DETALLE : EN PLANTA



**PROBLEMA # 02:** DISEÑAR LA ZAPATA COMBINADA PARA LA SECCIÓN DE MOMENTO MÁXIMO.

$Pd_1 = 35 \text{ ton}$   
 $PL_1 = 14 \text{ ton}$

$Pd_2 = 48 \text{ ton}$   
 $Pd_2 = 18 \text{ ton}$

$f_c = 210 \text{ kg/cm}^2$   
 $f_y = 4200 \text{ kg/cm}^2$

$\sigma_7 = 2.20 \text{ kg/cm}^2$ ,  $s/c = 200 \text{ kg/m}^2$ ,

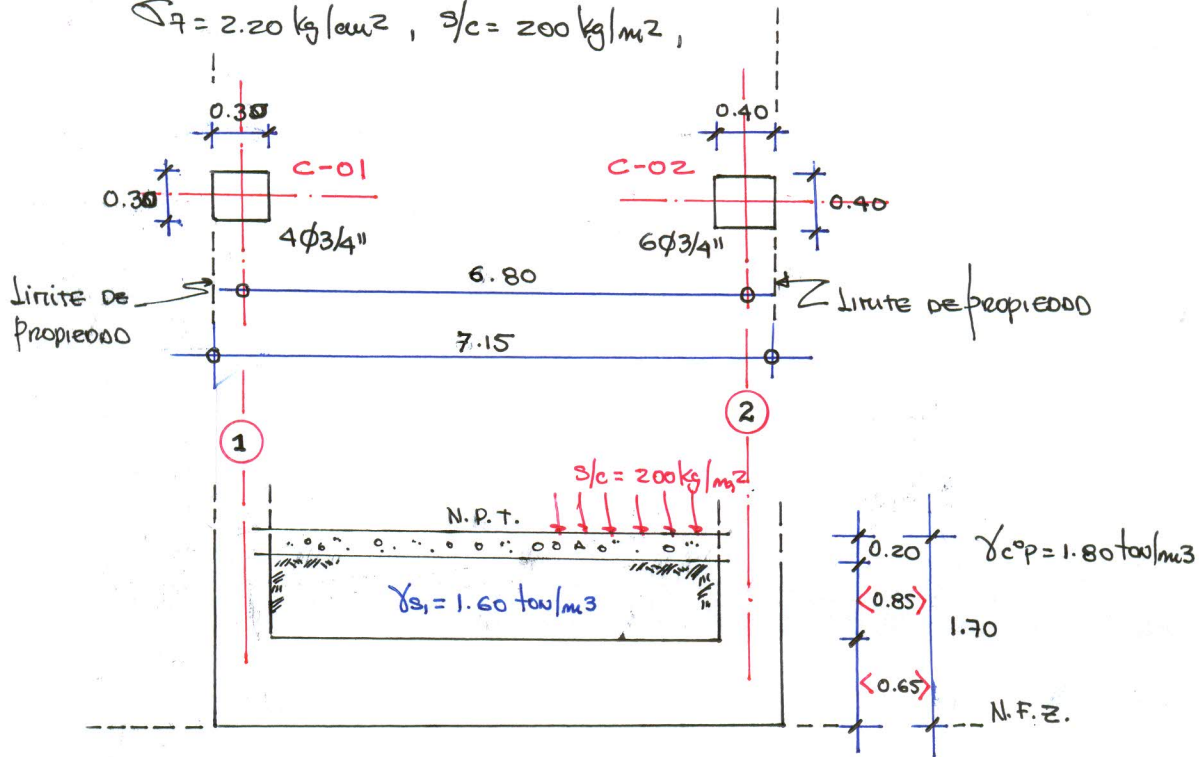

DIMENSIONAMIENTO:

▲ PERALTE: ACERO EN COLUMNA  $\phi 3/4 \Rightarrow db = 1.905 \text{ cm} = 0.01905 \text{ m}$ ,  $Ab = 2.84 \text{ cm}^2$ .

Consideraciones normativas:  $ld$  por compresión

$ld = 0.08 db fy / \sqrt{fc}$   
 $ld = 0.004 db fy$   
 $ld \geq 20 \text{ cm}$

$ld = 44.17 \text{ cm}$   
 $ld = 32.004 \text{ cm}$   
 $d = 20 \text{ cm}$

$\Rightarrow ld = 45 \text{ cm}$   
 $d = 55 \text{ cm}$   
 $h = 65 \text{ cm}$

CAPACIDAD PORTANTE NETA DEL TERRENO ( $q_e$ )

$q_e = \sigma_7 - (\gamma_{e2} \times h_2) - (\gamma_{s1} \times h_{s1}) - (\gamma_{cp} \times h_p) - s/c$   
 $= 22.00 - (2.40 \times 0.65) - (1.60 \times 0.85) - (1.80 \times 0.20) - 0.20$

$q_e = 18.52 \text{ ton/m}^2 = 1.852 \text{ kg/cm}^2$

Soluciones:

CARGAS DE SERVICIO:  $P_{S1} = P_{D1} + P_{L1} \Rightarrow P_{S1} = 35 + 14 \Rightarrow P_{S1} = 49 \text{ ton}$   
 $P_{S2} = P_{D2} + P_{L2} \Rightarrow P_{S2} = 48 + 18 \Rightarrow P_{S2} = 66 \text{ ton}$   
 $P_S = 115 \text{ ton}$

CARGAS ULTIMAS:  $P_{U1} = 1.70 P_{L1} + 1.40 P_{D1} \Rightarrow P_{U1} = 1.70(14) + 1.40(35) \Rightarrow P_{U1} = 72.80 \text{ ton}$   
 $P_{U2} = 1.70 P_{L2} + 1.40 P_{D2} \Rightarrow P_{U2} = 1.70(18) + 1.40(48) \Rightarrow P_{U2} = 97.80 \text{ ton}$   
 $P_U = 170.60 \text{ ton}$

Area Requerida (A)

$A = \frac{P_S}{\phi R} \Rightarrow A = \frac{115.00}{18.52} \Rightarrow A = 6.21 \text{ m}^2$

$L = 7.15 \text{ m}$   
 $b = 0.90 \text{ m}$   
 $A = 6.44 \text{ m}^2$

MAGNITUD Y UBICACION DE LA RESULTANTE:

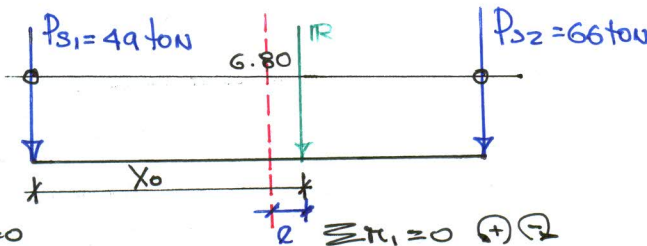

$\sum F_y = 0$   
 $-49 - 66 - R = 0$   
 $-R = 115 \text{ ton}$

$\sum M_i = 0$   
 $-R(X_0) - 66(6.80) = 0$   
 $X_0 = 3.903 \text{ m}$

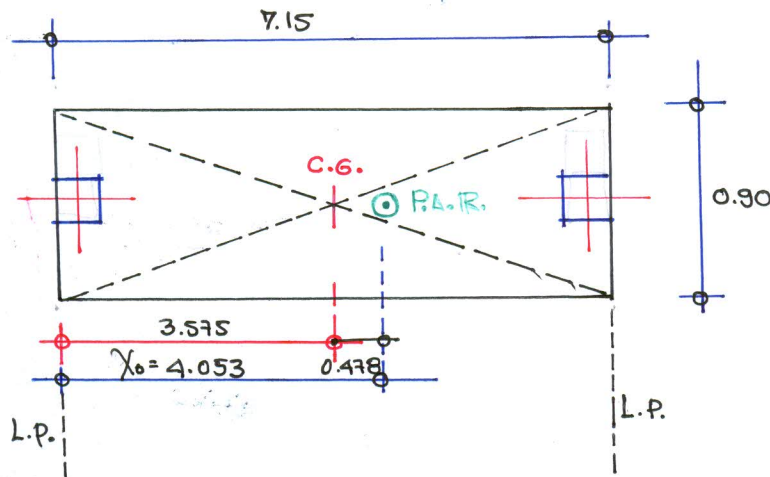

$e_s = X_0 - \frac{L}{2} \Rightarrow e_s = 4.053 - 3.575 \Rightarrow e_s = 0.478 < \frac{L}{6} = 1.192 \text{ m}$

Presión de contacto  $f$  (trapezoidal)

$M_s = P_S \times e_s \Rightarrow M_s = 115.00 \times 0.478 \Rightarrow M_s = 54.97 \text{ ton-m}$

VERIFICACION DE PRESION  $\sigma_{max} < \sigma_f$ 

$$P_s = 115.00 \text{ ton}, M_s = 54.97 \text{ ton-m}, A = 6.435 \text{ m}^2$$

$$\sigma_{max} = \frac{P_s}{A} + \frac{M_s c}{I}$$

$$c = \frac{L}{2} \Rightarrow c = 3.575 \text{ m}$$

$$I = \frac{B L^3}{12} \Rightarrow I = 27.414 \text{ m}^4$$

$$\sigma_{max} = \frac{115}{6.435} + \frac{54.97(3.575)}{27.414}$$

$$\sigma_{max} = 25.040 \text{ ton/m}^2 > \sigma_f = 22.00 \text{ ton/m}^2 \text{ REVISIONARLOS } B =$$

$$L = 7.15 \text{ m.}$$

$$B = 1.05 \text{ m.}$$

$$A = 7.508 \text{ m}^2$$

$$c = 3.575 \text{ m.}$$

$$I = 31.984 \text{ m}^4$$

$$\Rightarrow \sigma_{max} = 21.461 \text{ ton/m}^2 < \sigma_f = 22.00 \text{ ton/m}^2$$

∴ CONFORME

CARGAS DE DISEÑO  $P_u, M_u$ 

$$\sum F_x = 0$$

$$-P_{u1} - P_{u2} - R = 0$$

$$-72.80 - 97.80 = R$$

$$R = 170.60 \text{ ton}$$

$$\sum M_i = 0 \text{ (+) (-)}$$

$$-R(x_0) - P_{u2}(6.80) = 0$$

$$x_0 = \frac{97.80(6.80)}{170.60} \Rightarrow x_0 = 3.898 \text{ m}$$

$$\Rightarrow \phi_u = x_0 - \frac{L}{2} \Rightarrow \phi_u = 3.898 - \frac{7.15}{2} \Rightarrow \phi_u = 0.323 \text{ m} < \frac{L}{6} = 1.192 \text{ m}$$

$$M_u = P_u * \phi_u \Rightarrow M_u = 170.60 * 0.323 \Rightarrow M_u = 55.104 \text{ ton-m.}$$

## Reaccion Amplificada del suelo

$$\sigma_{1,2} = \frac{P_u}{A} \pm \frac{M_u(c)}{I}$$

$$P_u = 170.60 \text{ ton}, M_u = 55.104 \text{ ton-m}$$

$$A = 6.435 \text{ m}^2, B = 1.05 \text{ m}, L = 7.15 \text{ m}$$

$$c = 3.575 \text{ m}, I = 31.984 \text{ m}^4$$

$$\sigma_1 = 32.670 \text{ ton/m}^2$$

$$\sigma_2 = 20.352 \text{ ton/m}^2$$

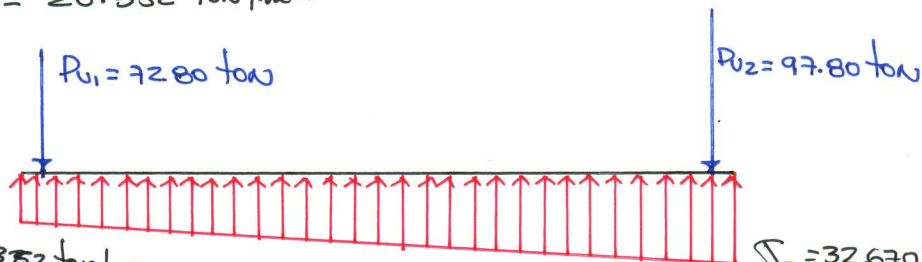

$$\sigma_2 = 20.352 \text{ ton/m}^2$$

$$\sigma_2 = 21.37 \text{ ton/m}^2$$

$$\sigma_2 = 32.670 \text{ ton/m}^2$$

$$\sigma_2 = 34.304 \text{ ton/m}^2$$



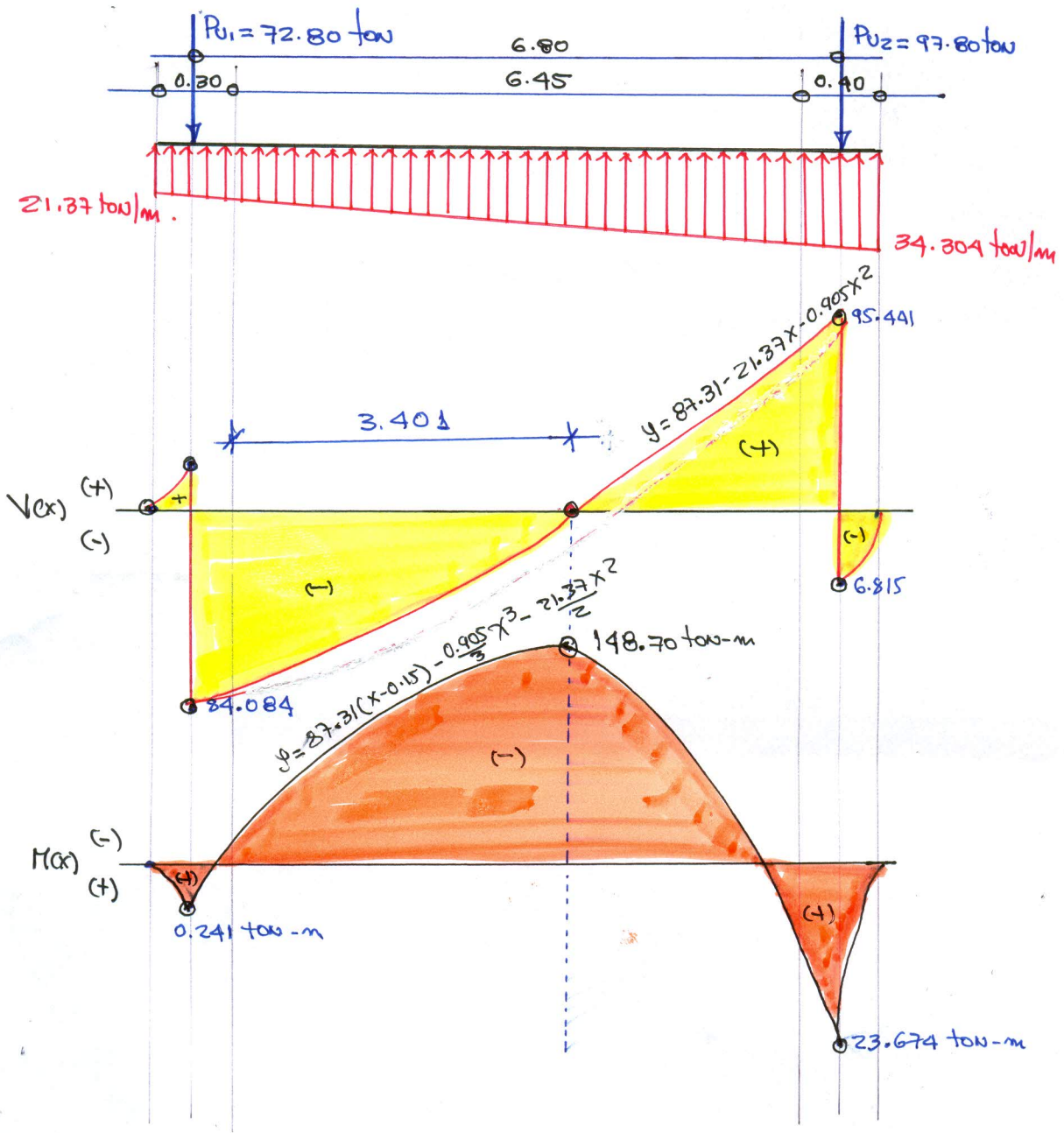

## ZAPATAS COMBINADAS

UNA CIMENTACIÓN COMBINADA RECIBE LAS CARGAS PROVENIENTES DE LA SUPER ESTRUCTURA A TRAVÉS DE 2 OTRAS COLUMNAS, SE USA PRINCIPALMENTE EN LOS SIGUIENTES CASOS:

- a) CUANDO DOS COLUMNAS ESTAN RELATIVAMENTE CERCANA ENTRE SI, DE TUDO QUE SE UNIRAN LAS ZAPATAS AISLADAS ESTAS PODRAN TRANSFORMARSE EN UNA ZAPATA COMBINADA.

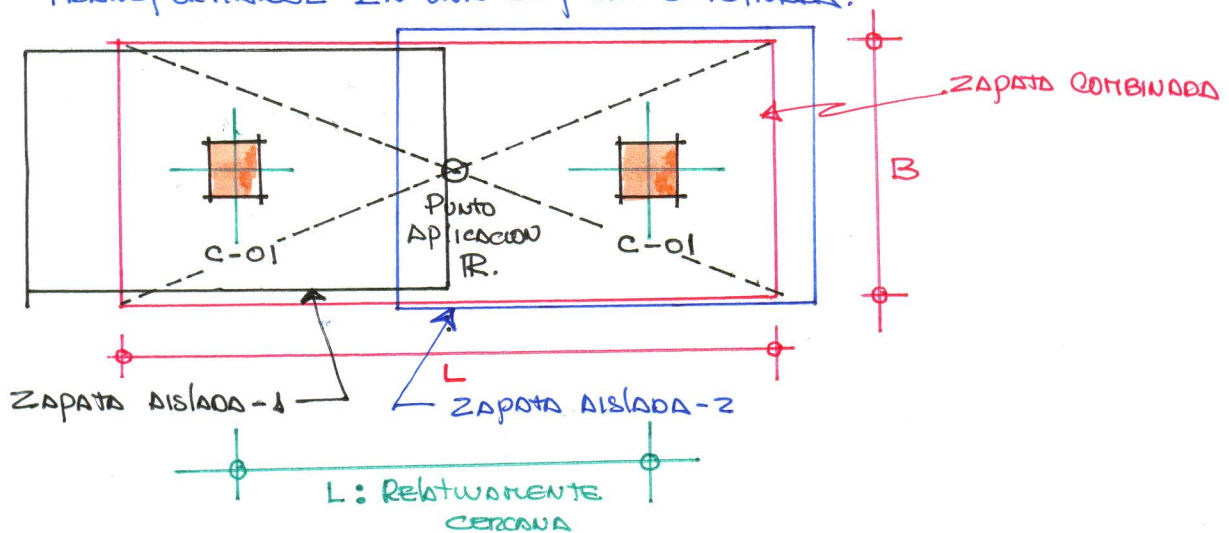

- b) CUANDO UNA COLUMNA EXTERIOR ESTA EN EL LIMITE DE PROPIEDAD O MUY CERCANA DE EL, DE TUDO QUE SE UNIRA UNA ZAPATA AISLADA ESTA RESULTARIA CON CARGA EXCENTRICA EXCESIVA.

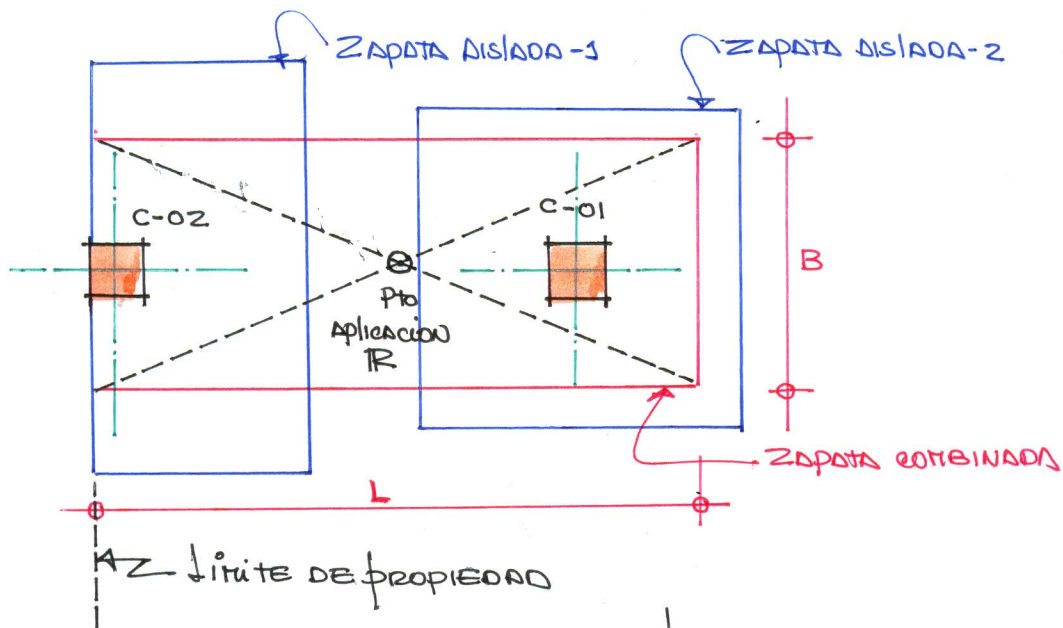

EN AMBOS CASOS EL FACTOR ECONOMICO TAMBIEN ES DETERMINANTE

PROBLEMA N° 01:

DISEÑAR LA ZAPATA COMBINADA DE LA FIG. MOSTRADO PARA LAS SOLICITACIONES INDICADAS:

$P_{cm1} = 55 \text{ ton}$   
 $P_{cv1} = 45 \text{ ton}$

$P_{cm2} = 90 \text{ ton}$   
 $P_{cv2} = 70 \text{ ton}$

$f'_c = 280 \text{ kg/cm}^2$   
 $f_y = 4200 \text{ kg/cm}^2$

$\gamma_s = 2.40 \text{ kg/cm}^2$

$NF = -1.80 \text{ m.}$

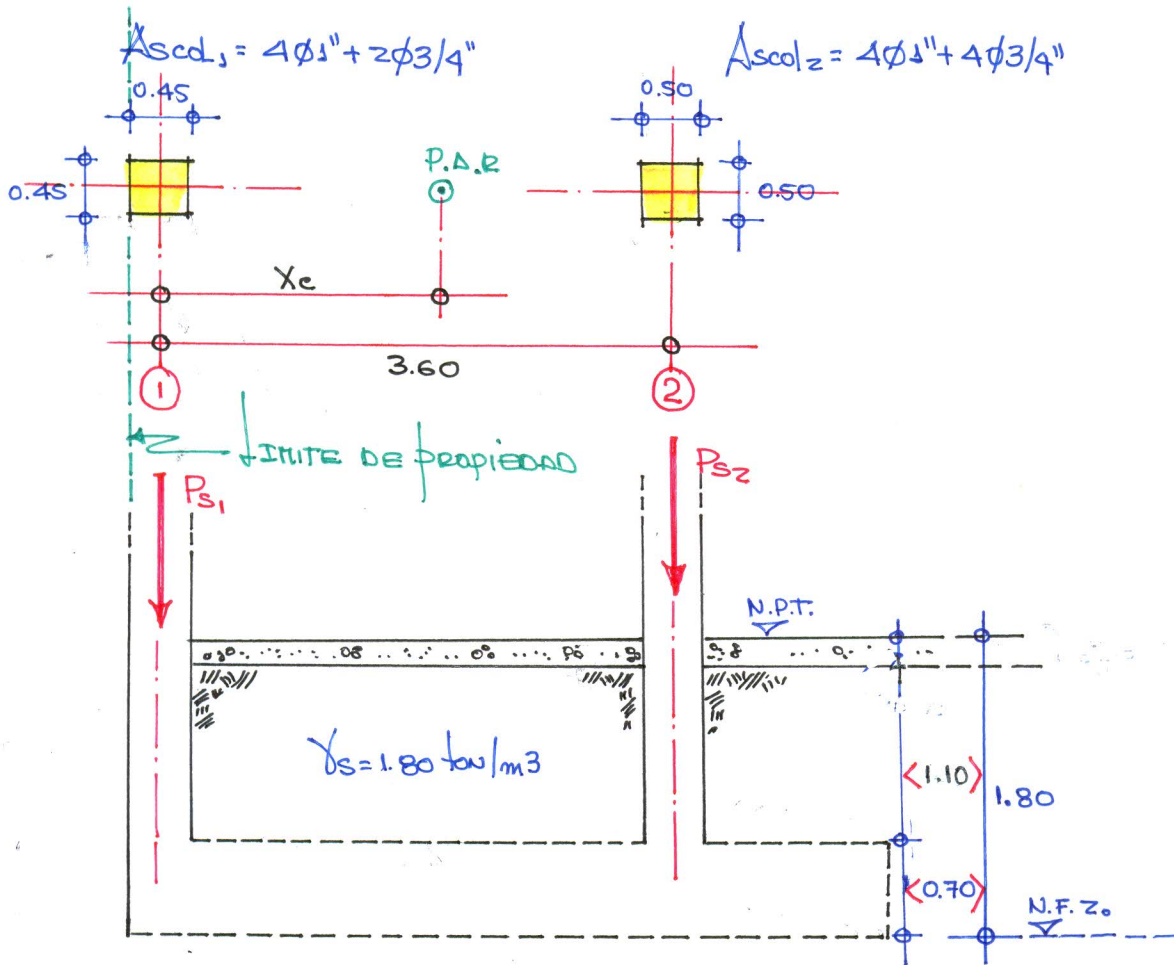

DIMENSIONAMIENTO:

4 PERALTE: Acero columna c-02:  $4\phi 1" + 4\phi 3/4" \Rightarrow \phi 1"$   $\left\{ \begin{array}{l} db = 2.54 \text{ cm.} \\ \Delta b = 5.10 \text{ cm}^2 \end{array} \right.$

Consideraciones Normativas

$Ld = 0.08 db f_y / \sqrt{f'_c}$

$Ld = 51.003 \text{ cm.}$

$Ld = 0.004 db f_y$

$Ld = 42.672 \text{ cm.} \Rightarrow Ld = 50 \text{ cm.}$

$Ld \geq 20 \text{ cm.}$

$Ld = 20.00 \text{ cm}$



$$l_d = 50 \text{ cm} \Rightarrow d = 60 \text{ cm}, \quad \therefore h = 170 \text{ cm.}$$

### ▲ Capacidad portante neta del terreno: ( $q_e$ )

$$q_e = \sigma_1 - (\gamma_c z_c \times h_z) - (\gamma_s \times h_s) \Rightarrow q_e = 20.34 \text{ ton/m}^2$$

$$q_e = 2.034 \text{ kg/cm}^2$$

### ▲ Solicitaciones

↳ Cargas de Servicio:  $P_{s1} = P_{c11} + P_{c12} \Rightarrow P_{s1} = 55 + 45 \Rightarrow P_{s1} = 100 \text{ ton}$

↳ Cargas últimas:  $P_{s2} = P_{c21} + P_{c22} \Rightarrow P_{s2} = 90 + 70 \Rightarrow P_{s2} = 160 \text{ ton}$

$$P_s = 260 \text{ ton}$$

$$P_{u1} = 1.40 P_{c11} + 1.70 P_{c12} \Rightarrow P_{u1} = 1.40(55) + 1.70(45) \Rightarrow P_{u1} = 153.50 \text{ ton}$$

$$P_{u2} = 1.40 P_{c21} + 1.70 P_{c22} \Rightarrow P_{u2} = 1.40(90) + 1.70(70) \Rightarrow P_{u2} = 245.00 \text{ ton}$$

$$P_u = 398.50 \text{ ton}$$

### ▲ Área requerida:

$$A = \frac{P_s}{q_e} \Rightarrow A = \frac{260.00}{20.34} \Rightarrow A = 12.783 \text{ m}^2$$

### ▲ Magnitud de la Resultante

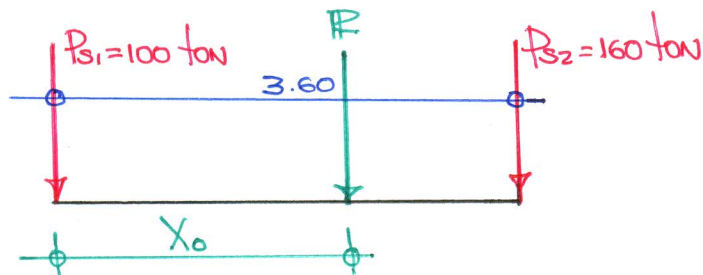

$$\sum F_v = 0$$

$$-100 - 160 - R = 0$$

$$R = -260 \text{ ton} \downarrow$$

$$\sum M_b = 0 \quad (+) \quad (-)$$

$$-R(x_0) - 160(3.60) = 0$$

$$x_0 = 2.22 \downarrow$$

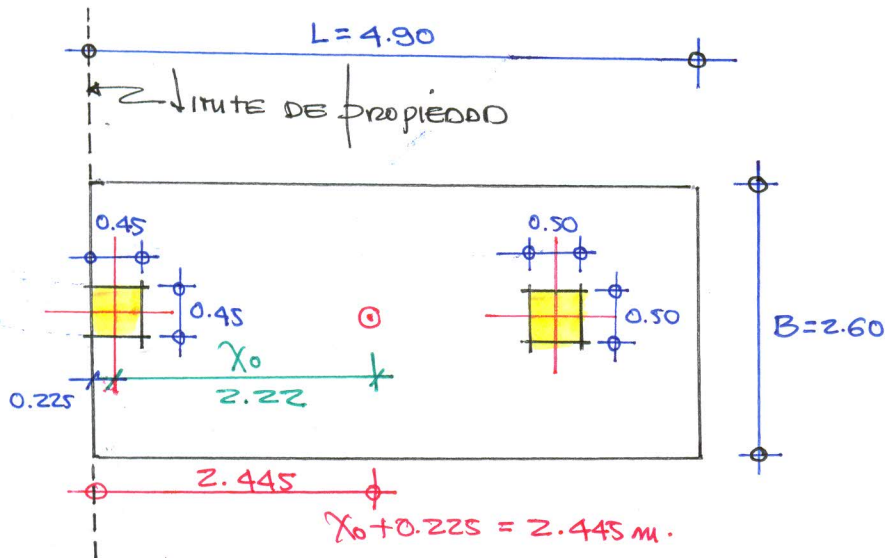

LONGITUD DE LA ZAPATA  $\downarrow = 2(2.445) \Rightarrow L = 4.89 \Rightarrow \underline{L = 4.90 \text{ m}}$

$\circ \circ \ B = \frac{A}{L} \Rightarrow B = \frac{12.783}{4.90} \Rightarrow B = 2.609 \text{ m} \longrightarrow \underline{B = 2.60 \text{ m}}$

$\underline{A = 12.74 \text{ m}^2}$

PRESIONES DE DISEÑO :

$P_{u1} = 153.50 \text{ ton}$   
 $P_{u2} = 245.00 \text{ ton}$   
 $P_u = 398.50 \text{ ton}$

L CARGAS DISTRIBUIDAS :

$A = 12.74 \text{ m}^2$ ,  $L = 4.90 \text{ m}$ ,  $B = 2.60 \text{ m}$ .

$\boxed{q'_u = \frac{P_u}{A}} \Rightarrow q'_u = \frac{398.50}{12.74} \Rightarrow q'_u = 31.279 \text{ ton/m}^2$

$\circ \circ \ q_u = 31.279 \text{ (B)}$

$q_u = 31.279 (2.60)$

$\underline{q_u = 81.327 \text{ ton/m}}$

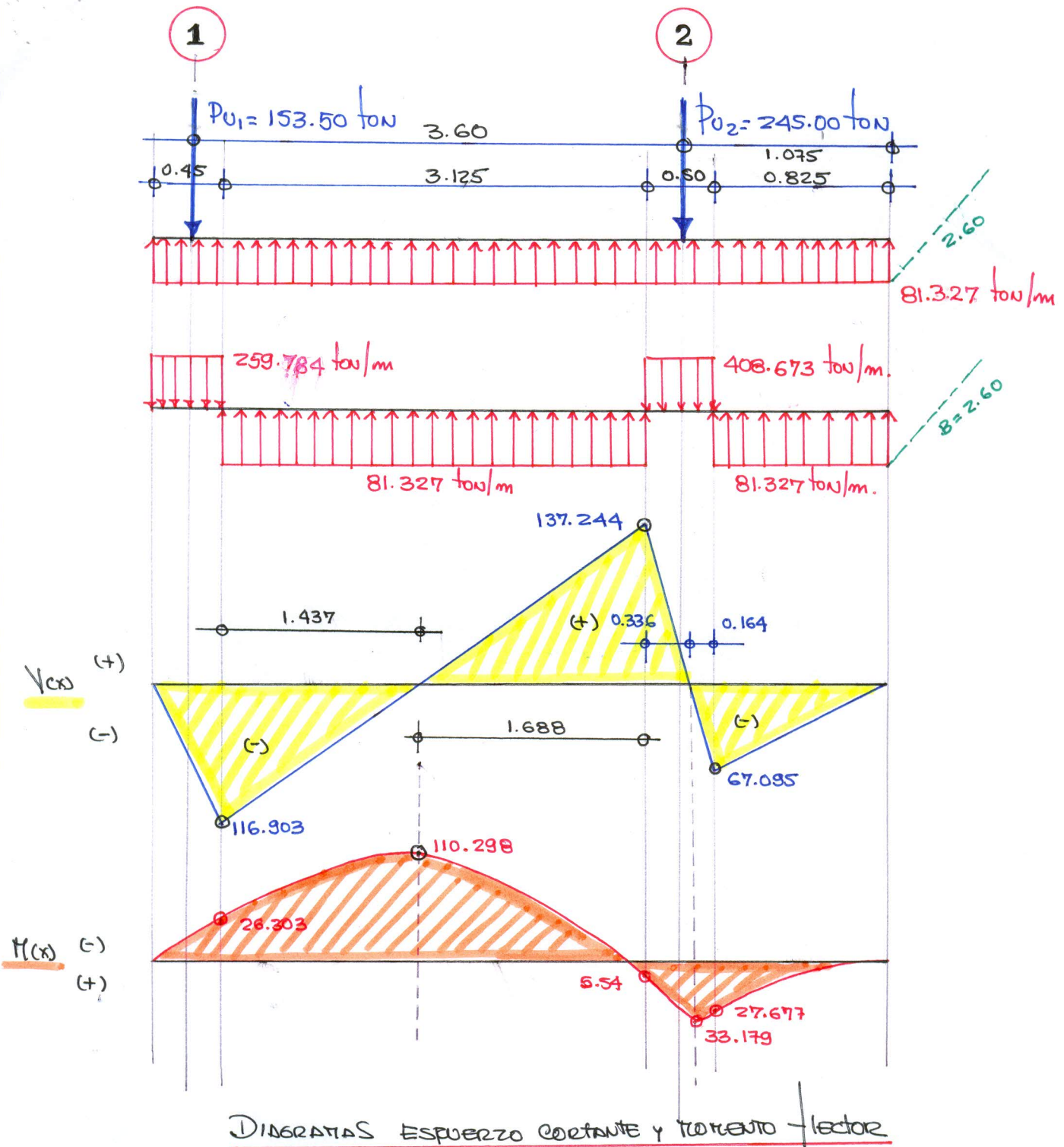



VERIFICACION Corte flexion:  $B=2.60$ ,  $L=4.90$ ,  $A=12.74 \text{ m}^2$   $d=60 \text{ cm}$ .

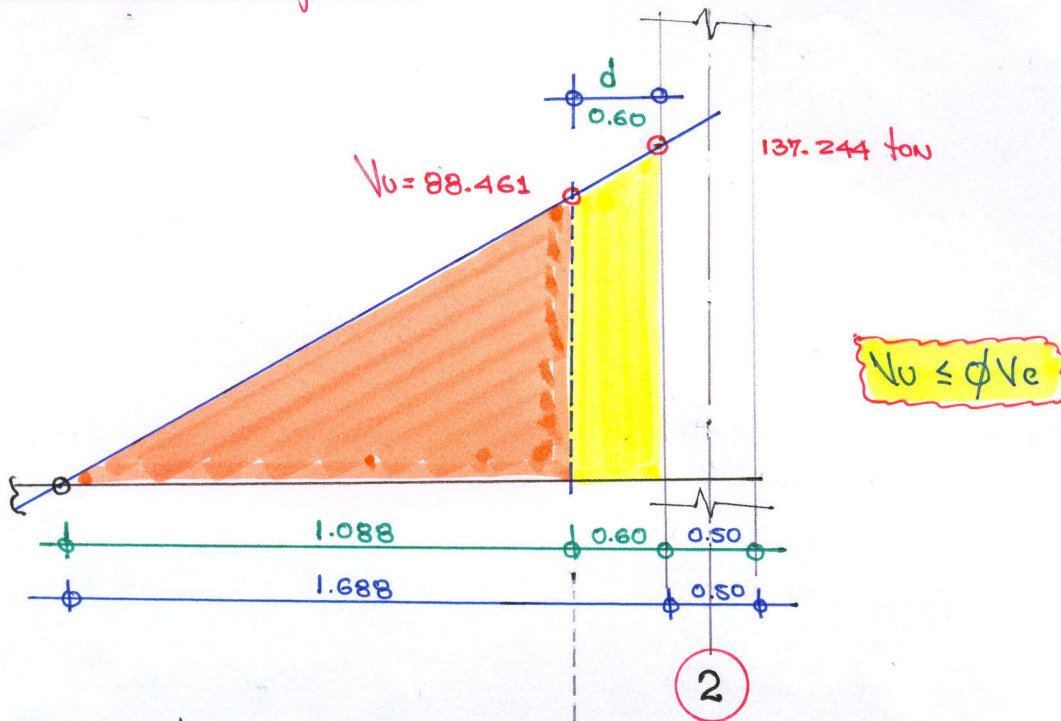

$V_u = 88.461 \text{ ton}$        $\phi V_c = \phi 0.53 \sqrt{f_c} B d = 0.85 \times 0.53 \sqrt{28} \times 260 \times 60 = 117.597 \text{ ton}$

$V_u = 88.461 \text{ ton} < \phi V_c = 117.597 \text{ ton}$  (cumple) **comportarse**

VERIFICACION FOR FONZONAMIENTO

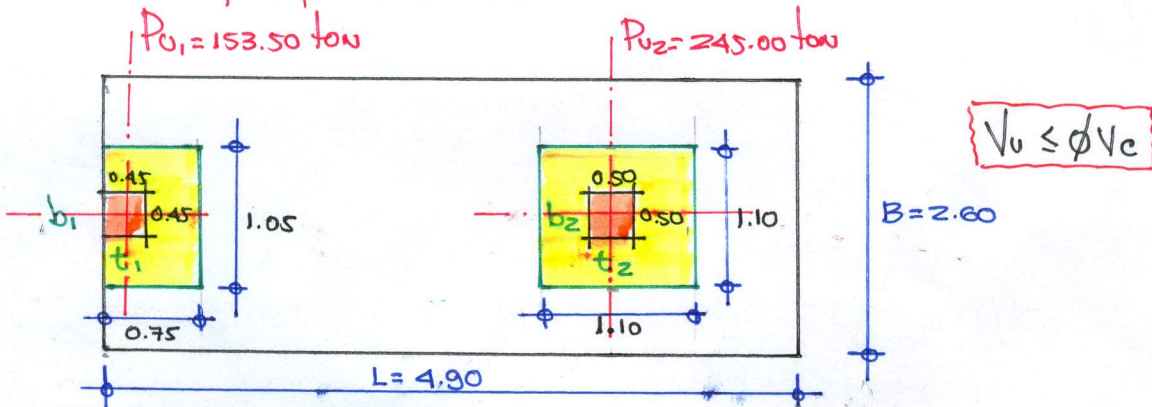

COLUMNA EXTERIOR

$V_u = P_{u1} - q_u [(t_1 + \frac{d}{2})(b_1 + d)]$

$V_u = 153.50 - 31.279 [(.45 + 0.30)(.45 + 0.60)]$

$V_u = 128.868 \text{ ton}$

$\phi V_c = \phi 1.10 \sqrt{f_c} b_o d$

$\phi V_c = 0.85 \times 1.10 \sqrt{280} \times 240 \times 60$

$\phi V_c = 225.296 \text{ ton}$

$V_u < \phi V_c$  (Comportarse)

COLUMNA INTERIOR

$V_u = P_{u2} - q_u [(t_2 + d)(b_2 + d)]$

$V_u = 245.00 - 31.279 [(.50 + 0.60)(.50 + 0.60)]$

$V_u = 207.152 \text{ ton}$

$\phi V_c = \phi 1.10 \sqrt{f_c} b_o d$

$\phi V_c = 0.85 \times 1.10 \sqrt{280} \times 440 \times 60$

$\phi V_c = 413.042 \text{ ton}$

$V_u < \phi V_c$  (Comportarse)

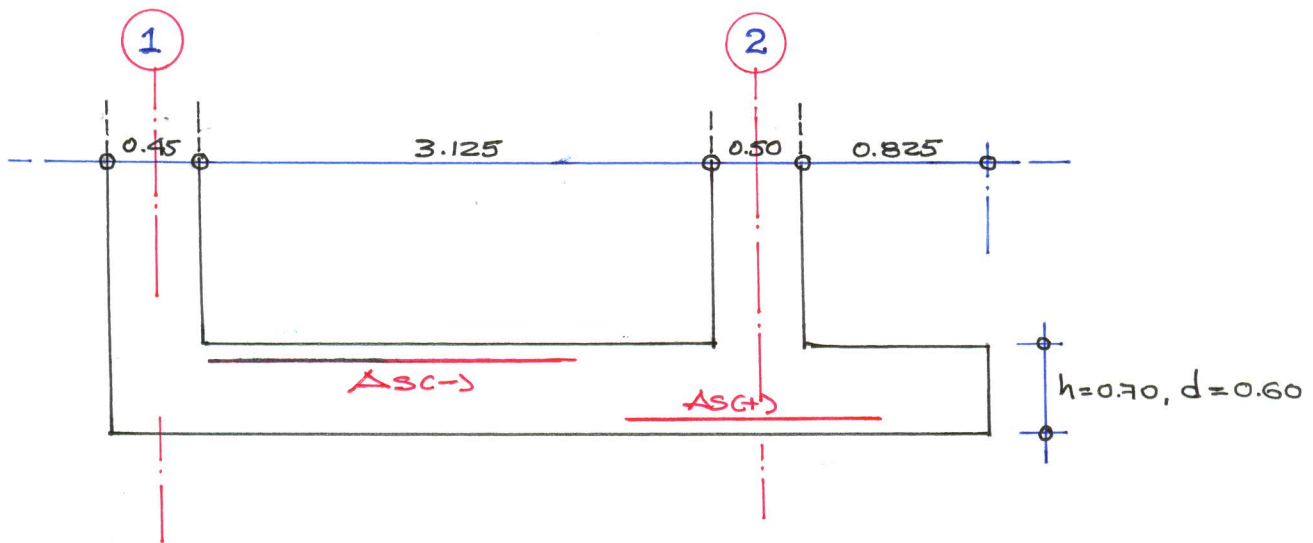

DISEÑO DE REFUERZO LONGITUDINAL:

① TRAMO: 1-2 ACERO NEGATIVO

DATOS DE DISEÑO:

$M_u = 110.298 \text{ ton}\cdot\text{m}$      $f_c = 280 \text{ kg/cm}^2$   
 $b = 260 \text{ cm}$ ,  $d = 60 \text{ cm}$ .     $f_y = 4200 \text{ kg/cm}^2$

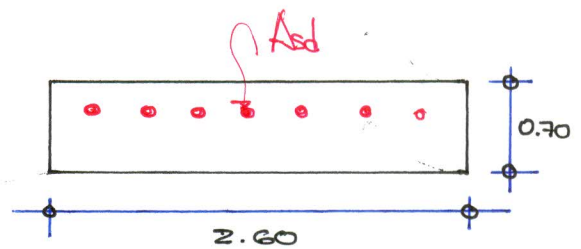

$$\alpha = \frac{A_s f_y}{0.85 f_c b}$$

$$M_u = \phi A_s f_y (d - \alpha/2)$$

$$\rho_{min} = \frac{0.70 \sqrt{f_c}}{f_y}$$

$$\rho_{min} = 0.00279 \Rightarrow A_{smin} = \rho_{min} b d \Rightarrow A_{smin} = 43.506 \text{ cm}^2$$

$$\rho_b = 0.85 \beta_1 \frac{f_c}{f_y} \left( \frac{6000}{6000 + f_y} \right)$$

$$\rho_b = 0.02833 \Rightarrow A_{sb} = \rho_b b d \Rightarrow A_{sb} = 441.948$$

$$\rho_d = w \frac{f_c}{f_y}$$

$$\rho_{max} = 0.75 \rho_b$$

$$\rho_d = 0.00321 \Rightarrow A_{sd} = \rho_d b d \Rightarrow A_{sd} = 50.054$$

$$\rho_{max} = 0.02125 \Rightarrow A_{smax} = \rho_{max} b d \Rightarrow A_{smax} = 331.50$$

DISTRIBUCIÓN DE REFUERZO:

$\phi 3/4 = 2.84 \text{ cm}^2$ ,  $db = 0.01905 \text{ cm}$ .

$\Rightarrow$  ACERO TMINIMO:  $A_{smin} = 43.506 \text{ cm}^2$ ,  $m = \frac{A_{smin}}{A_{s\phi}} \Rightarrow m = \frac{43.506}{2.84} \Rightarrow m = 15 \text{ UNIDADES}$

$\circ \circ S = \frac{2.60 - 0.15 - 0.01905 - 0.10}{14} \Rightarrow S = 0.166 \Rightarrow S = 0.17 \text{ cm}$

$\Rightarrow$  ACERO DE REFUERZO:  $A_{sr} = A_{sd} - A_{smin} \Rightarrow A_{sr} = 6.548 \text{ cm}^2$

$m = \frac{A_{sr}}{A_{s\phi}} \Rightarrow m = \frac{6.548}{2.84} \Rightarrow m = 2 \text{ UNIDADES}$ .  $\Rightarrow S = 0.75$

$\circ \circ A_{smin}: 15 \phi 3/4 @ 0.17$ ,  $A_{sr}: 2 \phi 3/4 @ 0.75$



## ② APOYO 2: ACERO POSITIVO

DATOS DE DISEÑO:  $M_u = 33.179 \text{ ton}\cdot\text{m}$        $f'_c = 280 \text{ kg/cm}^2$   
 $b = 260 \text{ cm}$ ,  $d = 60 \text{ cm}$ ,       $f_y = 4200 \text{ kg/cm}^2$

$$a = \frac{A_s f_y}{0.85 f'_c b} \Rightarrow M_u = \phi A_s f_y (d - a/2)$$

$$\rho_{\min} = 0.70 \sqrt{f'_c} / f_y \Rightarrow \rho_{\min} = 0.00279 \quad A_{s\min} = \rho_{\min} b d \Rightarrow A_{s\min} = 43.506 \text{ cm}^2$$

$$\rho_b = 0.85 \beta \frac{f'_c}{f_y} \left( \frac{6000}{6000 + f_y} \right) \Rightarrow \rho_b = 0.02833 \quad A_{sb} = \rho_b b d \Rightarrow A_{sb} = 441.948 \text{ cm}^2$$

$$\rho_d = w f'_c / f_y \Rightarrow \rho_d = 0.00095 \quad A_{sd} = \rho_d b d \Rightarrow A_{sd} = 14.753 \text{ cm}^2$$

$$\rho_{\max} = 0.75 \rho_b \Rightarrow \rho_{\max} = 0.02125 \quad A_{s\max} = \rho_{\max} b d \Rightarrow A_{s\max} = 331.50 \text{ cm}^2$$

∴  $A_{sd} = A_{s\min} = 43.506 \text{ cm}^2$

DISTRIBUCION DE REFUERZO:  $\phi 3/4" = 2.84 \text{ cm}^2$ ,  $d_b = 0.01905 \text{ cm}$ .

$$n = \frac{A_{sd}}{A_{\phi}} \Rightarrow n = \frac{43.506}{2.84} \Rightarrow n = 15.319 \Rightarrow n = 15 \text{ UNIDADES}$$

$$s = \frac{2.60 - 0.15 - 0.01905 - 0.10}{19} \Rightarrow s = 0.1665 \Rightarrow s = 0.17 \text{ m}$$

15  $\phi 3/4" @ 0.17$

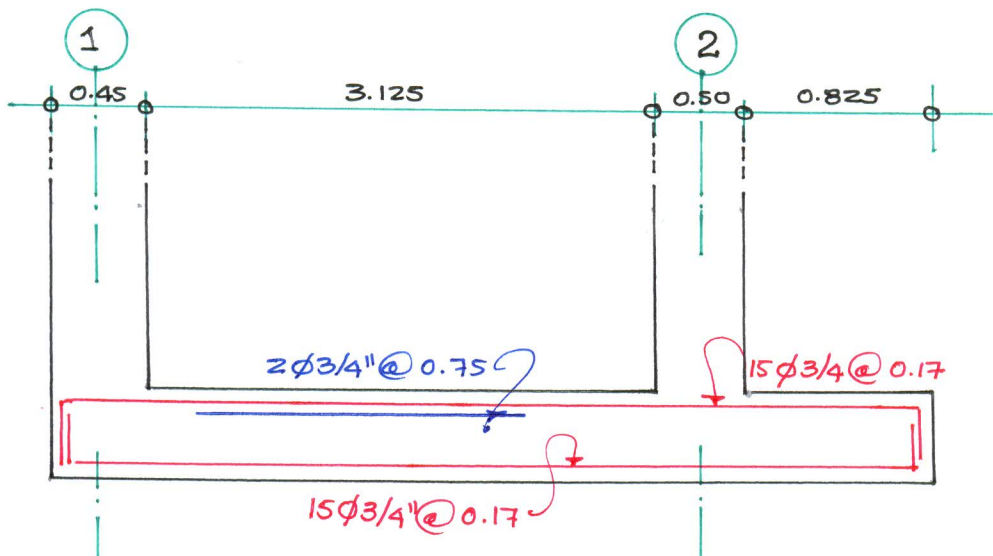

DETALLE: REFUERZO LONGITUDINAL



DISEÑO DE FUERZO TRANSVERSAL

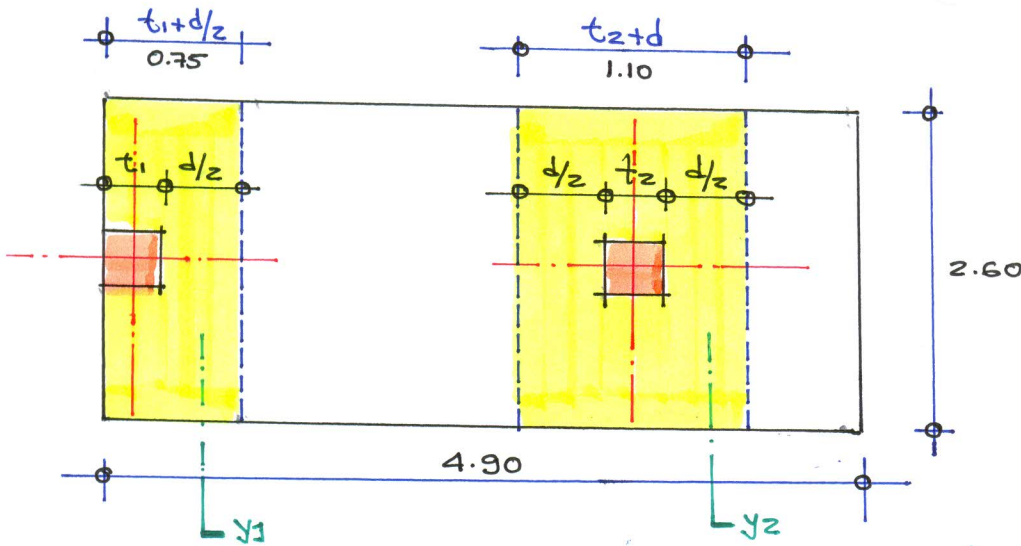

COLUMNA EXTERIOR (y1-y1')

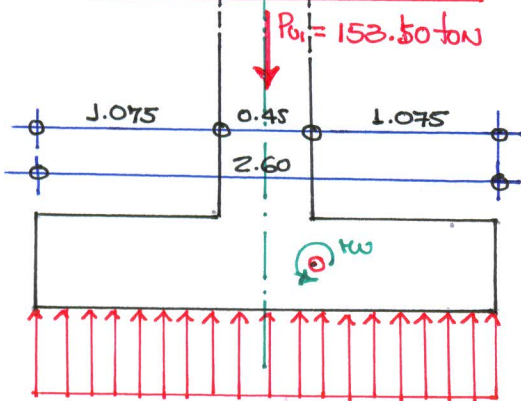

$$\frac{153.50}{2.60} = 59.038 \text{ ton/m}$$

$$M_u = \frac{wL^2}{2} \Rightarrow Kw = 34.113 \text{ ton-m}$$

$$b = 100 \text{ cm}, d = 60 \text{ cm}, f_c = 280 \text{ kg/cm}^2, f_y = 4200 \text{ kg/cm}^2$$

- $P_{kw} = 0.00279$       $A_{stkw} = 16.733 \text{ cm}^2$
- $P_b = 0.02833$       $A_{sb} = 169.98 \text{ cm}^2$
- $P_d = 0.00257$       $A_{sd} = 15.39 \text{ cm}^2$
- $P_{max} = 0.02125$       $A_{smax} = 127.50 \text{ cm}^2$

$$\Rightarrow A_{sfd} = A_{sd} (0.75) \Rightarrow A_{sfd} = 11.54 \text{ cm}^2$$

$n = 4.06 \text{ 2nd}, n = 4 \text{ 2nd.}$

$$S = \frac{0.75 - 0.075 - 0.01905 - 0.10}{4} \Rightarrow S = 0.185 \text{ m}$$

$4 \phi 3/4 @ 0.185 \text{ m.}$

COLUMNA INTERIOR (y2-y2')

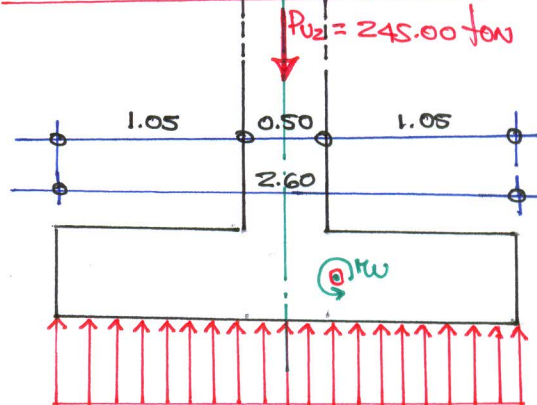

$$\frac{245}{2.60} = 94.231 \text{ ton/m.}$$

$$M_u = \frac{wL^2}{2} \Rightarrow Kw = 51.945 \text{ ton-m}$$

- $P_{kw} = 0.00279$       $A_{stkw} = 16.733 \text{ cm}^2$
- $P_b = 0.02833$       $A_{sb} = 169.98 \text{ cm}^2$
- $P_d = 0.00386$       $A_{sd} = 23.734 \text{ cm}^2$
- $P_{max} = 0.02125$       $A_{smax} = 127.50 \text{ cm}^2$

$$\Rightarrow A_{sfd} = A_{sd} (1.10) \Rightarrow A_{sfd} = 26.107 \text{ cm}^2$$

$n = 9.19 \text{ 2nd.} \Rightarrow n = 9 \text{ 2nd.}$

$$S = \frac{1.10 - 0.01905 - 0.10}{8} \Rightarrow S = 0.12 \text{ m.}$$

$8 \phi 3/4 @ 0.12 \text{ m.}$

ACERO DE MONTAJE:  $b = 100 \text{ cm}$ ,  $h = 70 \text{ cm}$ ,  $f_c = 280 \text{ kg/cm}^2$ ,  $f_y = 4200 \text{ kg/cm}^2$

$$A_{sR} = 0.0018 b h$$

$$A_{sR} = 0.0018 \times 100 \times 70 \Rightarrow A_{sR} = 12.60 \text{ cm}^2$$

$$S = \frac{b \times A_{s\phi}}{A_{sR}} \Rightarrow S = \frac{100 \times 2.84}{12.60} \Rightarrow S = 22.50 \text{ cm}$$

∴  $A_{sR}: \phi 3/4 @ 0.225$

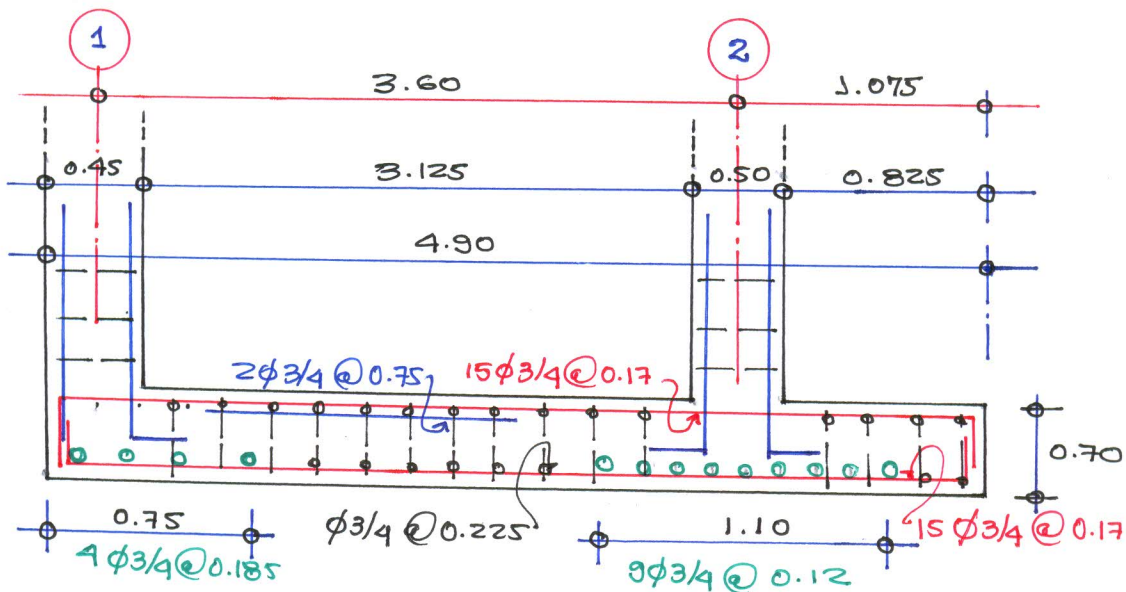

DETALLE DE REPUERZO LONGITUDINAL / TRANSVERSO